

DGC-K (eng)

(8182)63-90-72
+7(7172)727-132
(4722)40-23-64
(4832)59-03-52
(423)249-28-31
(844)278-03-48
(8172)26-41-59
(473)204-51-73
(343)384-55-89
(4932)77-34-06
(3412)26-03-58
(843)206-01-48

(4012)72-03-81
(4842)92-23-67
(3842)65-04-62
(8332)68-02-04
(861)203-40-90
(391)204-63-61
(4712)77-13-04
(4742)52-20-81
(3519)55-03-13
(495)268-04-70
(8152)59-64-93
(8552)20-53-41

(831)429-08-12
(3843)20-46-81
(383)227-86-73
(4862)44-53-42
(3532)37-68-04
(8412)22-31-16
(342)205-81-47
- - (863)308-18-15
(4912)46-61-64
(846)206-03-16
- (812)309-46-40
(845)249-38-78

:

(4812)29-41 -54
(862)225-72-31
(8652)20-65-13
(4822)63-31-35
(3822)98-41-53
(4872)74-02-29
(3452)66-21 -18
(8422)24-23-59
(347)229-48-12
(351)202-03-61
(8202)49-02-64
(4852)69-52-93

Linear drives DGC

Features

At a glance

- Without external guide, for simple drive functions
- Compact – fitting length relative to stroke
- Fully interchangeable with the linear drive DGP

- Easy assembly and installation
- Choice of:
 - Standard piston
 - Extended piston

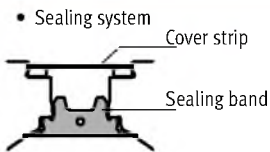

- Advantages of the sealing system:
- Long strokes with no restrictions
 - Virtually no leakage

- Optional: NSF-H1 lubricant for the food industry

The linear drive is of limited suitability for the food industry.

More information on suitability for use in the food industry
 → Manufacturer's declaration.

Guide variants

Compact design DGC-K



- Piston \varnothing 18 ... 80 mm
- Stroke lengths from 1 ... 8500 mm
- 30% narrower than the DGC-G
- Low moving dead weight
- Symmetrical design

Basic design DGC-G



- Piston \varnothing 8 ... 63 mm
- Stroke lengths from 1 ... 8500 mm
- Guide backlash = 0.2 mm
- For small loads
- Operating behaviour with torque load = average

Plain-bearing guide DGC-GF

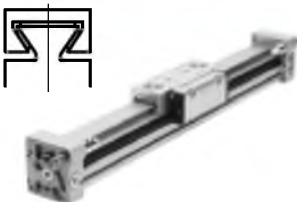

- Piston \varnothing 18 ... 63 mm
- Stroke lengths from 1 ... 8500 mm
- Guide backlash = 0.05 mm
- For small and medium loads
- Operating behaviour with torque load = average

Recirculating ball bearing guide DGC-KF

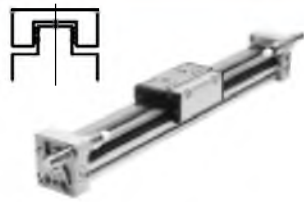

- Piston \varnothing 8 ... 63 mm
- Stroke lengths from 1 ... 8500 mm
- Guide backlash = 0 mm
- For medium and large loads
- Precision mounting interface with stainless steel slide
- Operating behaviour under torque load = very good

Heavy-duty guide DGC-HD

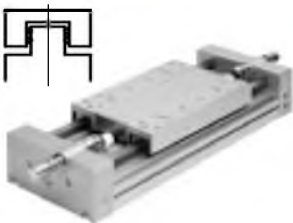

- Piston \varnothing 18, 25, 40 mm
- Stroke lengths from 10 ... 5000 mm
- Guide backlash = 0 mm
- For large loads
- Operating behaviour under torque load = very good

Passive guide axis DGC-FA



- Without drive
- Piston \varnothing 8 ... 63 mm
- Stroke lengths from 1 ... 8500 mm
- Guide backlash = 0 mm
- Precision guide, suitable for DGC-KF. Can be used as machine component or as twin guide with DGC-KF

D2 – Compressed air connection at both ends



The compressed air connections on the linear drive DGC-K are located on the end caps as standard.

The linear drive is actuated at both ends by specifying order code D2 in the modular product system. Actuation at one end is no longer possible.

Linear drives DGC

Features

Application examples

For opening and closing doors

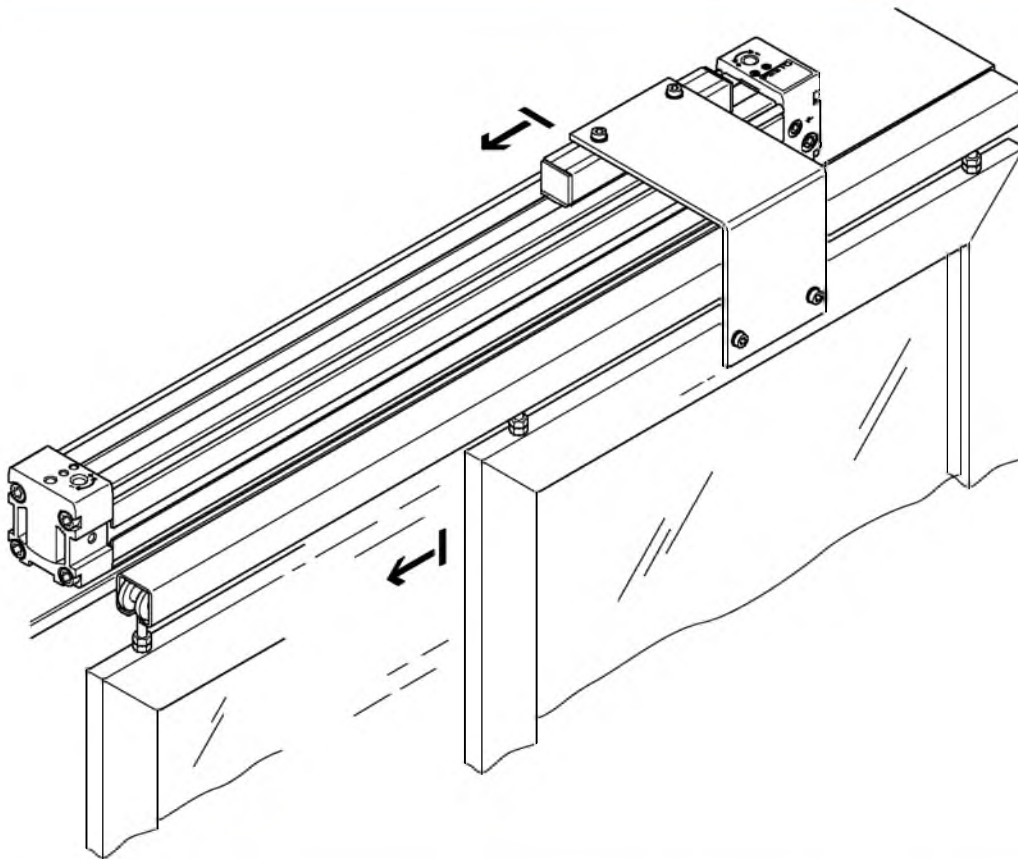

For transporting glass plates

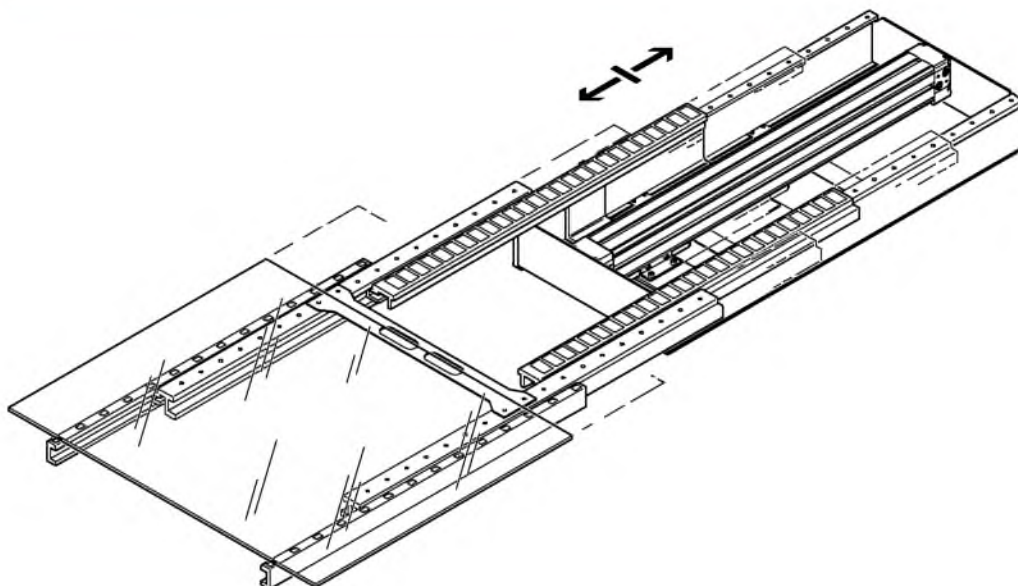



Linear drives DGC

Product range overview

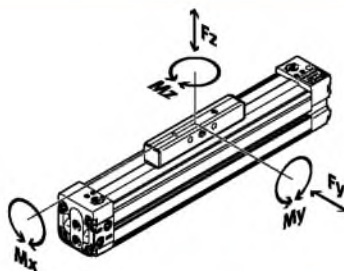
Product variants





	Piston \varnothing [mm]	Theoretical force at 6 bar [N]	Guide characteristics					→ Page/ Internet
			Fy [N]	Fz [N]	Mx [Nm]	My [Nm]	Mz [Nm]	
Compact design DGC-K								
	18	153	–	120	0.8	11	1	8
	25	295	–	330	1.2	20	3	
	32	483	–	480	1.9	40	5	
	40	754	–	800	3.8	60	8	
	50	1178	–	1200	6	120	15	
	63	1870	–	1600	5.7	150	24	
80	3016	–	2500	30.6	400	100		
Basic design DGC-G								
	8	30	150	150	0.5	2	2	dgc
	12	68	300	300	1.3	5	5	
	18	153	70	340	1.9	12	4	
	25	295	180	540	4	20	5	
	32	483	250	800	9	40	12	
	40	754	370	1100	12	60	25	
	50	1178	480	1600	20	150	37	
63	1870	650	2000	26	150	48		
Plain-bearing guide DGC-GF								
	18	153	440	540	3.4	20	8.5	dgc
	25	295	640	1300	8.5	40	20	
	32	483	900	1800	15	70	33	
	40	754	1380	2000	28	110	54	
	50	1178	1500	2870	54	270	103	
	63	1870	2300	4460	96	450	187	

Linear drives DGC

Product range overview

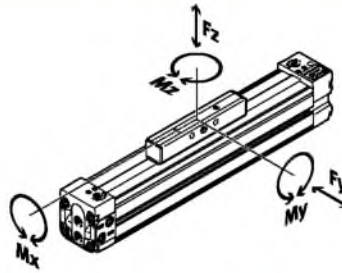
Product variants



	Piston Ø [mm]	Theoretical force at 6 bar [N]	Guide characteristics					→ Page/ Internet
			Fy [N]	Fz [N]	Mx [Nm]	My [Nm]	Mz [Nm]	
Recirculating ball bearing guide DGC-KF								
	8	30	300	300	1.7	4.5	4.5	dgc
	12	68	650	650	3.5	10	10	
	18	153	1850	1850	16	51	51	
	25	295	3050	3050	36	97	97	
	32	483	3310	3310	54	150	150	
	40	754	6890	6890	144	380	380	
	50	1178	6890	6890	144	634	634	
63	1870	15200	15200	529	1157	1157		
Heavy-duty guide DGC-HD								
	18	153	3650	3650	140	275	275	dgc-hd
	25	295	5600	5600	300	500	500	
	40	754	13000	13000	900	1450	1450	

Linear drives DGC-K

Type codes

DGC - K - 25 - 500 - PPV - A - GK - - - - FK - -

Type

DGC	Linear drive
-----	--------------

Guide

K	Compact
---	---------

Piston Ø [mm]

Stroke [mm]

Cushioning

PPV	Pneumatic cushioning, adjustable at both ends
-----	---

Position sensing

A	For proximity sensor
---	----------------------

Basic design

GK	Standard piston
GV	Extended piston

Compressed air connection

-	At one end
D2	At both ends

Lubrication

-	Standard
H1	Lubrication approved for use in food applications

Moment compensator

FK	Moment compensator coupling
----	-----------------------------

EU certification

EX2	II 3GD
EX3	II 2G

Linear drives DGC-K

Type codes



		+ ZUB	-	F			2B	2G			2S
Accessories											
ZUB	Accessories enclosed separately										
Foot mounting											
F	Foot mounting										
Profile mounting											
...M	Profile mounting										
Slot nut											
...Y	For mounting slot										
Slot cover											
...B	For mounting slot										
Proximity sensor, N/O contact											
...G	With cable, 2.5 m										
...H	With plug										
...I	Contactless with cable, 2.5 m										
...J	Contactless plug										
Proximity sensor, N/C contact											
...N	With cable, 7.5 m										
Connecting cable											
...V	With plug, 2.5 m										
Slot cover											
...S	For sensor slot										

Linear drives DGC-K

Peripherals overview

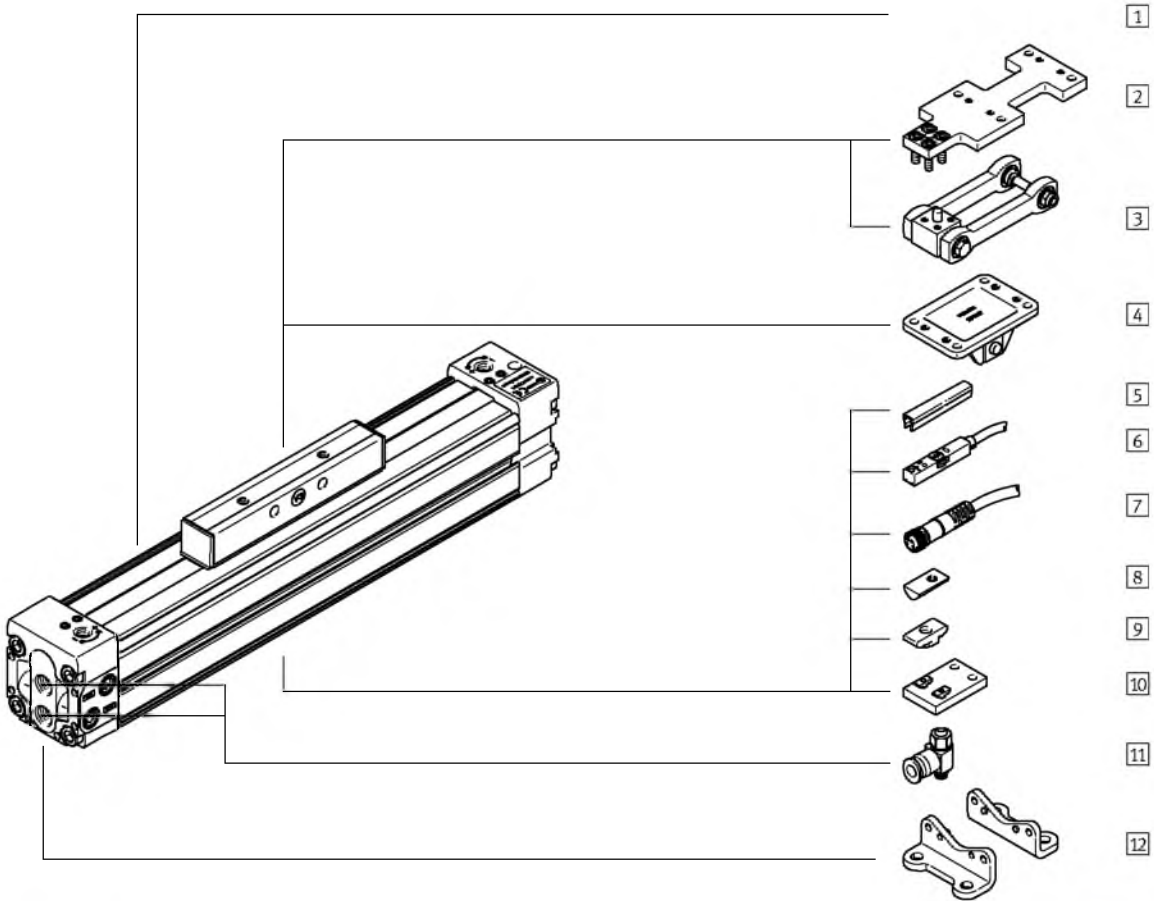

Product example



Linear drives DGC-K

Peripherals overview

Accessories		
Type/Order code	Description	→ Page/Internet
1 Linear drive DGC-K	Pneumatic linear drive with moment compensator	10
2 Adapter plate DAMF	Has the same interface as the moment compensator FKP with the linear drive DGP	32
3 Moment compensator DARD-...-M	For compensating misalignments when using external guides	30
4 Moment compensator FK (type: DARD-...-S)	For compensating misalignments when using external guides. Has the same interface as the moment compensator FKP with the linear drive DGP	28
5 Slot cover B/S	For protecting against the ingress of dirt and securing proximity sensor cables	34
6 Proximity sensor G/H/I/J/N	For sensing the moment compensator position	34
7 Connecting cable V	<ul style="list-style-type: none"> For proximity sensor 	35
8 Slot nut for mounting slot Y (type: NST)	<ul style="list-style-type: none"> For mounting components Piston \varnothing 18 and 25: cannot be used with DGC-...-D2 (Compressed air connection at both ends) 	34
9 Slot nut for mounting slot Y (type: ABAN)	<ul style="list-style-type: none"> For mounting components Piston \varnothing 18 and 25: possible with all combinations 	34
10 Central support M	For mounting the axis, particularly with long strokes	27
11 One-way flow control valve GRLA	For regulating speed	34
12 Foot mounting F	For mounting the axis	26

Linear drives DGC-K

Technical data

Function

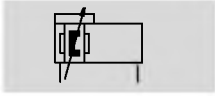

- ⌀ - Diameter
18 ... 80 mm
- - Stroke length
1 ... 8500 mm



General technical data								
Piston Ø		18	25	32	40	50	63	80
Design	Pneumatic linear drive with slide							
Guide	Slotted cylinder barrel							
Mode of operation	Double-acting							
Stroke	[mm]	1 ... 3000	1 ... 8500			1 ... 6000	1 ... 5000	1 ... 3000 ¹⁾
Pneumatic connection		M5	G $\frac{1}{8}$		G $\frac{1}{4}$		G $\frac{3}{8}$	G $\frac{1}{2}$
Cushioning	PPV	Adjustable at both ends						
Cushioning length	[mm]	16	18	20	30	30	30	83
Max. speed								
With PPV cushioning	[m/s]	2						
With external cushioning	[m/s]	3						
Position sensing		For proximity sensor						
Type of mounting		With accessories						
Mounting position		Any						

1) Additional strokes on request.

Operating and environmental conditions									
Piston Ø		18	25	32	40	50	63	80	
Operating pressure	[bar]	2 ... 8				1.5 ... 8			
Operating medium		Compressed air in accordance with ISO 8573-1:2010 [7:-:-]							
Note on the operating/control medium		Lubricated operation possible (required during subsequent operation)							
Ambient temperature ¹⁾	[°C]	-10 ... +60							
Food-safe ²⁾		See supplementary material information							
Corrosion resistance class CRC ³⁾		1							

ATEX ¹⁾	
Explosion-proof temperature rating	-10°C ≤ Ta ≤ +60°C
CE marking (see declaration of conformity)	As per EU Explosion Protection Directive (ATEX)
EX2 certification	
ATEX category for gas	II 3G
Explosion ignition protection type for gas	c T4 X
ATEX category for dust	II 3D
Explosion ignition protection type for dust	c T120°C X
EX3 certification	
ATEX category for gas	II 2G
Explosion ignition protection type for gas	c T4 X

1) Note the ATEX certification of the accessories.

Linear drives DGC-K

Technical data

Forces [N] and impact energy [J]							
Piston Ø	18	25	32	40	50	63	80
Theoretical force at 6 bar	153	295	483	754	1178	1870	3016
Max. impact energy in the end positions ¹⁾	0.04	0.05	0.12	0.25	0.5	0.5	3

1) Permissible residual impact energy following PPV cushioning

Weight [g]							
Piston Ø	18	25	32	40	50	63	80
Basic weight with 0 mm stroke							
DGC-...-GK	370	933	1319	2450	5438	8620	16775
DGC-...-GV	630	1343	1999	3620	8073	13000	-
Additional weight per 10 mm stroke							
DGC-...-GK	18	29	37	53	100	137	157
DGC-...-GV	18	29	37	53	100	137	-
Moving load							
DGC-...-GK	64	136	227	360	1095	1782	5000
DGC-...-GV	130	261	427	700	1713	2704	-

Materials

Sectional view

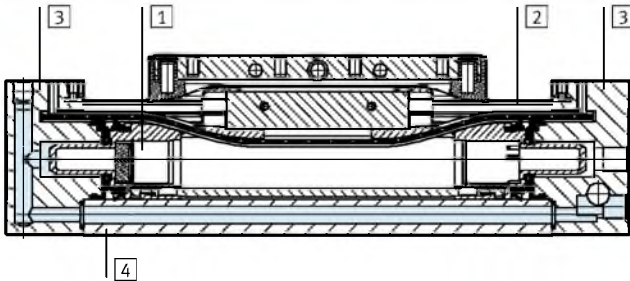

Linear drives	
1	Slide Anodised aluminium
2	Sealing band/cover band Polyurethane/steel
3	Cover Painted aluminium
4	Cylinder barrel Anodised aluminium
-	Piston seal Polyurethane
-	Slide elements Polyacetal
Note on materials RoHS-compliant	

Linear drives DGC-K

Technical data

Influence of ferritic materials on proximity sensors

Ferritic materials (steel parts or panels) directly next to the proximity sensors can cause sensing

malfunctions. The following safety distances must be observed.

The distance depends on the position of the proximity sensor (see [1] and [2]).

Piston Ø 18/25

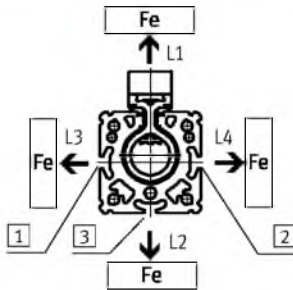

Piston Ø 32 ... 80

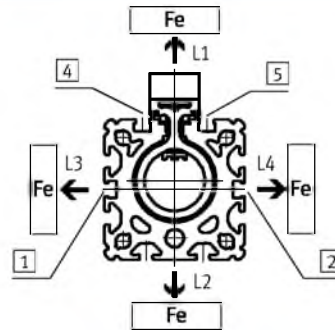

Position		L1	L2	L3	L4
Piston Ø 18					
[1]	[mm]	0	10	30	0
[2]	[mm]	0	10	0	30
[3]	[mm]	0	30	10	10
Piston Ø 25					
[1]	[mm]	0	0	10	0
[2]	[mm]	0	0	0	10
[3]	[mm]	0	10	0	0

Position		L1	L2	L3	L4
Piston Ø 32					
[1]	[mm]	0	0	10	0
[2]	[mm]	0	0	0	10
[4] and [5]	[mm]	10	0	0	0
Piston Ø 40					
[1]	[mm]	0	0	30	0
[2]	[mm]	0	0	0	30
[4] and [5]	[mm]	30	0	0	0
Piston Ø 50					
[1]	[mm]	0	0	10	0
[2]	[mm]	0	0	0	10
[4] and [5]	[mm]	10	0	0	0
Piston Ø 63					
[1]	[mm]	0	0	20	0
[2]	[mm]	0	0	0	20
[4] and [5]	[mm]	20	0	0	0
Piston Ø 80					
[1]	[mm]	0	0	10	0
[2]	[mm]	0	0	0	10
[4] and [5]	[mm]	10	0	0	0

Linear drives DGC-K

Technical data

Characteristic load values

The indicated forces and torques refer to the surface of the slide. These values must not be exceeded during dynamic operation. Special attention must be paid to the deceleration phase.

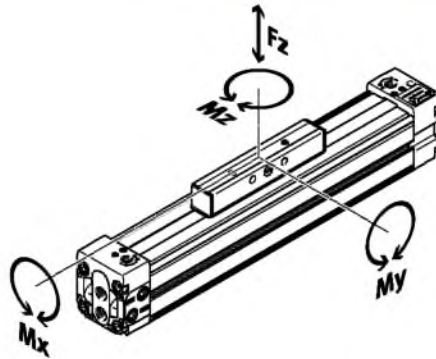

Comparison of the reference system with DGC-K and DGP:

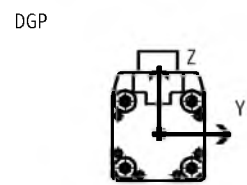
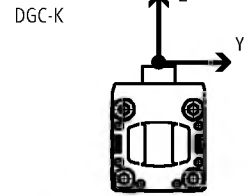

If the drive is simultaneously subjected to several of the forces and torques indicated below, the following equations must be met in addition to the specified maximum loads:

$$0,4 \times \frac{Fz}{Fz_{max.}} + \frac{Mx}{Mx_{max.}} + \frac{My}{My_{max.}} + 0,2 \times \frac{Mz}{Mz_{max.}} \leq 1$$

$$\frac{Fz}{Fz_{max.}} \leq 1 \quad \frac{Mz}{Mz_{max.}} \leq 1$$

Permissible forces and torques								
Piston Ø		18	25	32	40	50	63	80
Fz_{max.}								
DGC-...-GK	[N]	120	330	480	800	1200	1600	2500
DGC-...-GV	[N]	120	330	480	800	1200	1600	-
Mx_{max.}								
DGC-...-GK	[Nm]	0.8	1.2	1.9	3.8	6	5.7	30.6
DGC-...-GV	[Nm]	1.6	2.4	3.8	7.6	12	11.4	-
My_{max.}								
DGC-...-GK	[Nm]	11	20	40	60	120	150	400
DGC-...-GV	[Nm]	22	40	80	120	240	300	-
Mz_{max.}								
DGC-...-GK	[Nm]	1	3	5	8	15	24	100
DGC-...-GV	[Nm]	2	6	10	16	30	48	-

Linear drives DGC-K

Technical data

Maximum permissible piston speed v as a function of effective load m and distance r_{max} from the centre of gravity of the load

These specifications represent the maximum values that can be achieved. In practice, these values can fluctuate relative to the position of the effective load and mounting position.

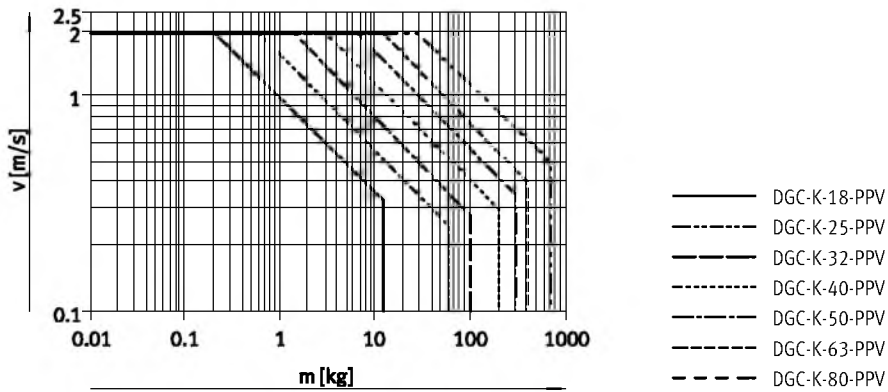

Operating range of the cushioning

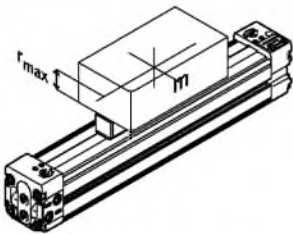

The end-position cushioning must be adjusted to ensure jerk-free operation. If the operating conditions are outside the permissible range, the

load to be moved must be cushioned using suitable equipment (external shock absorbers), preferably at the centre of gravity of the load.

Piston \varnothing	18	25	32	40	50	63	80
Distance r_{max} [mm]	14	40	40	40	40	40	40

Linear drives DGC-K

Technical data

Number of central supports MUP as a function of weight due to force F and distance between supports l

The drive may need to be supported to limit the deflection in the case of large strokes. The following diagrams

are provided to determine the maximum permissible distance between supports as a function of the installa-

tion position and the applied weight and normal forces.

Mounting position

Horizontal

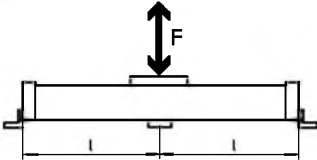

Vertical

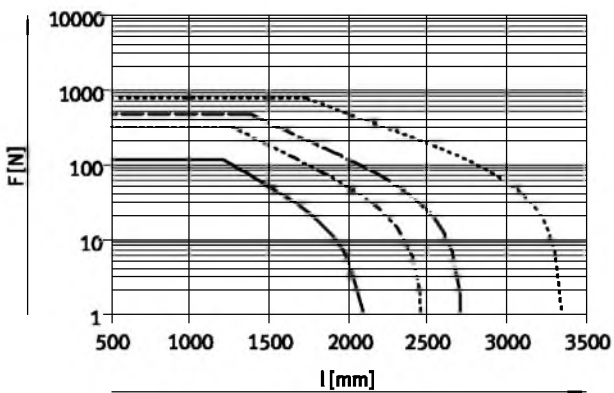
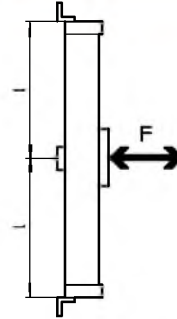

— DGC-K-18 - - - DGC-K-25
 - · - DGC-K-32 · · · DGC-K-40

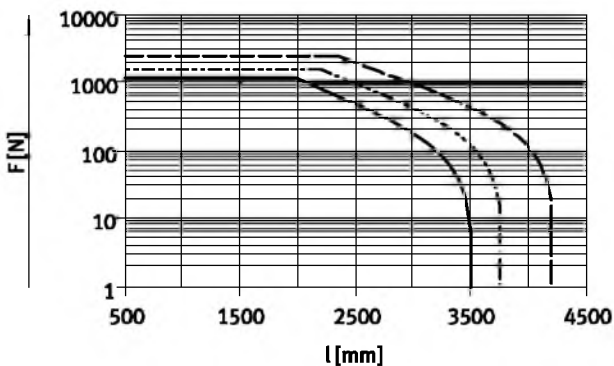
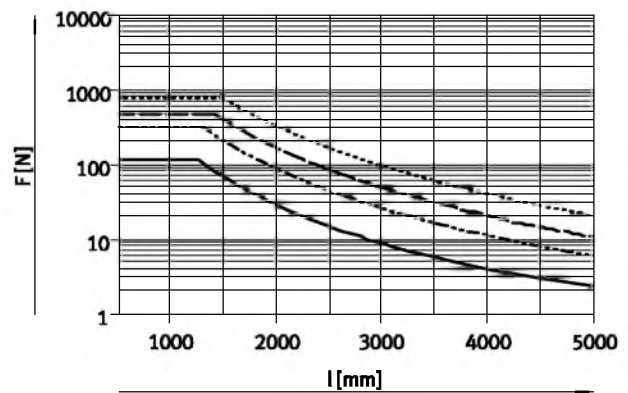

— DGC-K-50
 - - - DGC-K-63
 - · - DGC-K-80

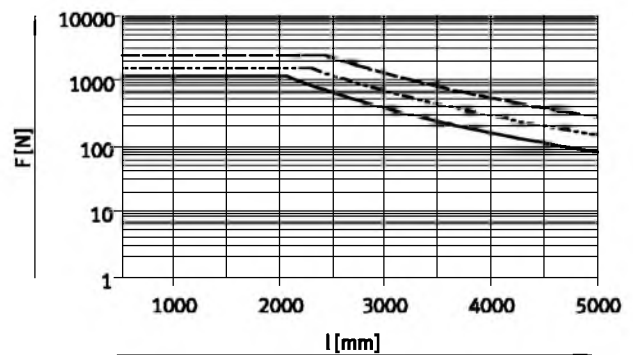

Example:

The drive DGC-K-25-1500 is subjected to a force of 200 N in horizontal assembly position.

The drive has an overall length of:
 $l = \text{stroke length} + L1$
 (see dimensions)
 $= 1500 \text{ mm} + 200 \text{ mm}$
 $= 1700 \text{ mm}$

According to the graph, the max. support span for the drive DGC-K-25 with a force of 200 N is 1450 mm.

In this example, central supports are required as the max. support distance (1450 mm) is smaller than the total length of the drive (1700 mm).

Linear drives DGC-K

Technical data

Dimensions

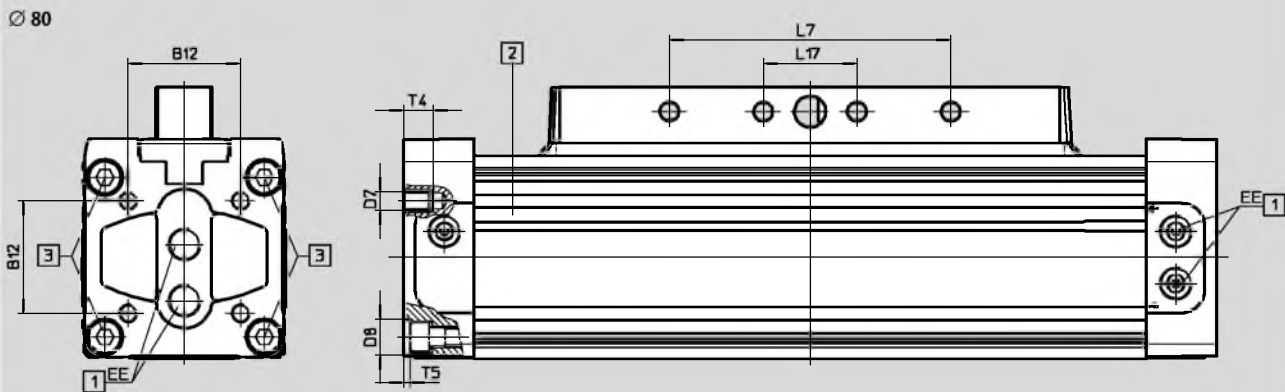
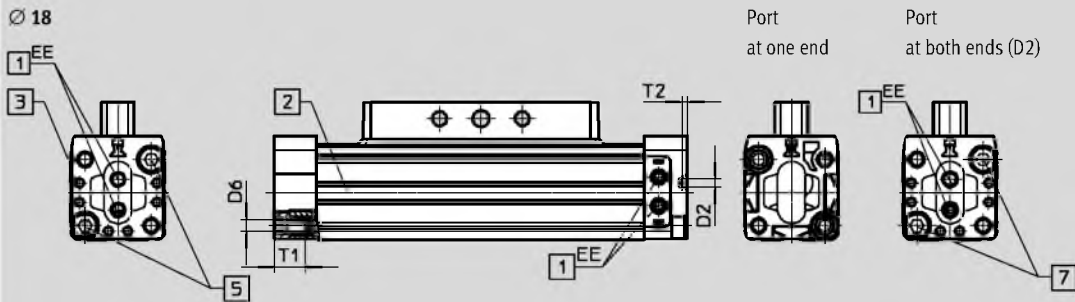
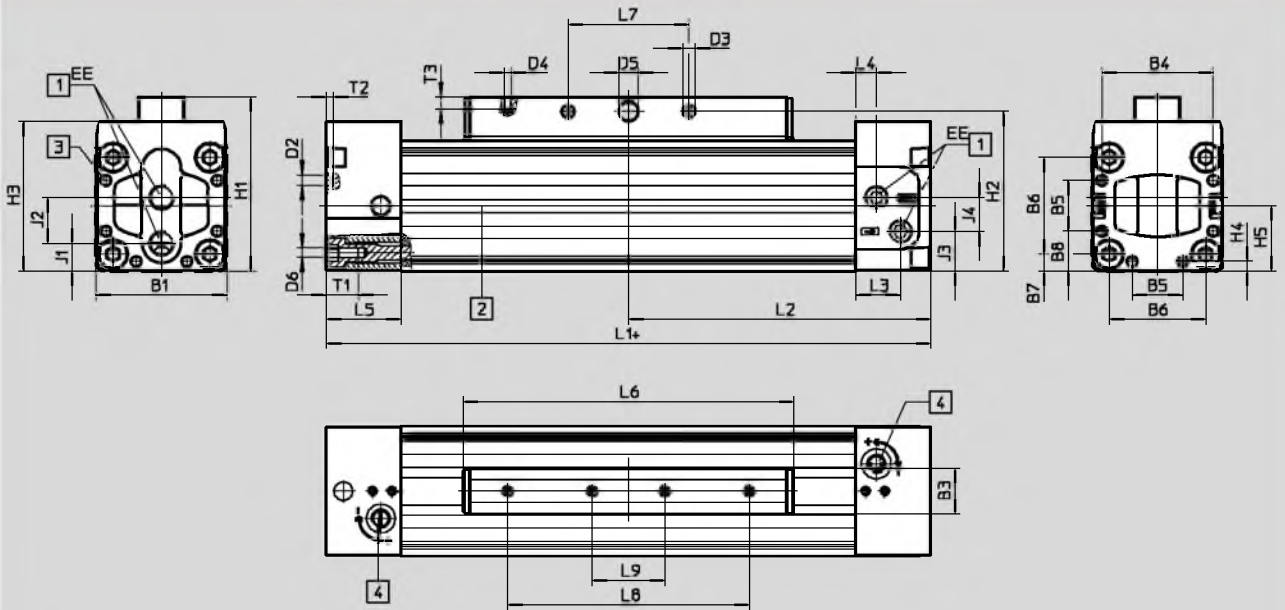

+ plus stroke length

1 Supply port options on 3 sides

2 Slot for proximity sensor

3 Mounting holes for foot mounting HP

4 Regulating screw for adjustable end-position cushioning

5 No mounting thread with Ø 18

7 No mounting thread with Ø 18, in combination with variant D2

Linear drives DGC-K

Technical data

∅ [mm]	B1	B3 ±0.2	B4	B5	B6	B7	B8	B12	D2 ∅	D3 ∅ +0.2
18	34 ^{+0.2/-0.05}	12	28	7	24	5	13.5	-	3	5.2
25	45 ^{+0.4}	19	39.1	18	32.5	6.3	13.5	-	3.3	5.2
32	54 ^{+0.4}	19	46	21	40	7	16.5	-	4.3	5.2
40	64 ^{+0.4}	21	53	28	49	7,5	18	-	4.3	6.5
50	90 ^{+0.4}	24	76	44	72	9	23	-	6.3	8.5
63	106 ^{+0.4}	24	89	44	83	11.5	31	-	6.3	8.5
80	130 ^{+0.8}	36	-	-	102	14	29	72	-	12.2

∅ [mm]	D4	D5 ∅	D6	D7	D8 ∅	EE	H1	H2	H3	H4	H5
18	M5	6 ^{H7}	M5	-	-	M5	49.8	43.8	37.6	3	17
25	M5	8 ^{H7}	M4	-	-	G1/8	63	57	51	3	22.5
32	M5	8 ^{H7}	M5	-	-	G1/8	72	66	61.8	4	27
40	M6	10 ^{H7}	M5	-	-	G1/4	86	78	71.8	5.5	32
50	M8	12 ^{H7}	M6	-	-	G1/4	115	106	99	7	45
63	M8	12 ^{H7}	M8	-	-	G3/8	131	122	115	8.5	53
80	M12	20 ^{H10}	-	M12	23	G1/2	174	158	140.5	-	85

∅ [mm]	J1	J2	J3	J4	L1		L2		L3	L4	L5
					GK	GV	GK	GV			
18	10.7	11.1	12.2	10.4	150	230	75	115	5	5	15.5
25	9	16.7	15.7	13	200	300	100	150	17	7	25
32	11.4	19	17.1	14	250	380	125	190	18.5	8.5	31
40	13.5	22	19.5	21	300	470	150	235	11.5	11.5	31
50	21	30.8	27	29.3	350	550	175	275	14	14	34
63	25	36	32	33	400	650	200	325	13.5	13.5	34
80	37	36	48.1	33.3	520	-	260	-	19	19	45

∅ [mm]	L6		L7	L8	L9	L17 ±0,15	T1	T2	T3	T4	T5
	GK	GV									
18	85	165	30±0.1	60±0.1	-	-	11	2	10	-	-
25	109	209	30±0.1	50±0.1	-	-	13	2	7.5	-	-
32	135	265	50±0.1	100±0.1	30±0.1	-	13.2	3	7.5	-	-
40	171	341	70±0.1	130±0.1	40±0.1	-	13.2	4	10.5	-	-
50	206	406	80±0.1	150±0.1	50±0.1	-	15.2	6	12.5	-	-
63	234	484	110±0.1	190±0.1	70±0.1	-	21.2	6	12.5	-	-
80	334	-	180±0.15	230±0.15	115±0.15	60	-	-	19	18	4

Length tolerance										
For stroke	[mm]	≤ 1000	≤ 2000	≤ 3000	≤ 4000	≤ 5000	≤ 6000	≤ 7000	≤ 8000	≤ 9000
L1	[mm]	±0.45	±0.55	±0.70	±0.75	±0.80	±0.85	±1.10	±1.15	±1.20

Linear drives DGC-K

Technical data

Dimensions

GK – Standard piston

Ø 18

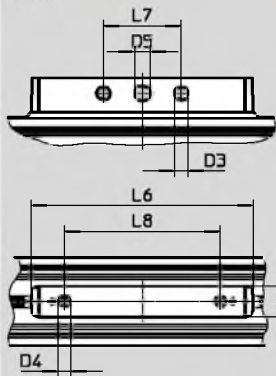

Ø 25

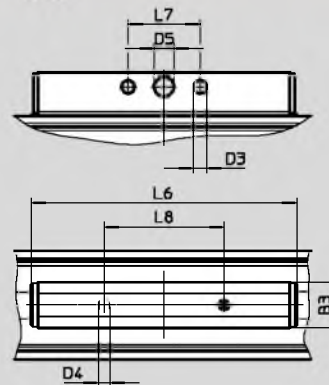

Ø 32

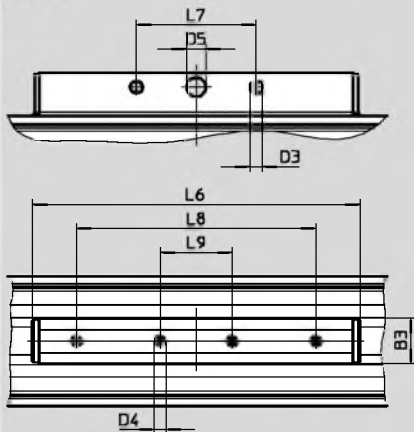

Ø 40

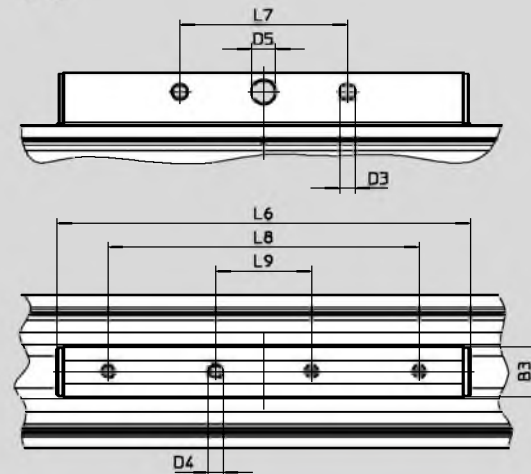

Ø	B3	D3	D4	D5	L6	L7	L8	L9
[mm]	±0.2	+0.2		Ø H7		±0.1	±0.1	±0.1
18	12	5.2	M5	6	85	30	60	-
25	19	5.2	M5	8	109	30	50	-
32	19	5.2	M5	8	135	50	100	30
40	21	6.5	M6	10	171	70	130	40

Linear drives DGC-K

Technical data

Dimensions

GK – Standard piston

Ø 50

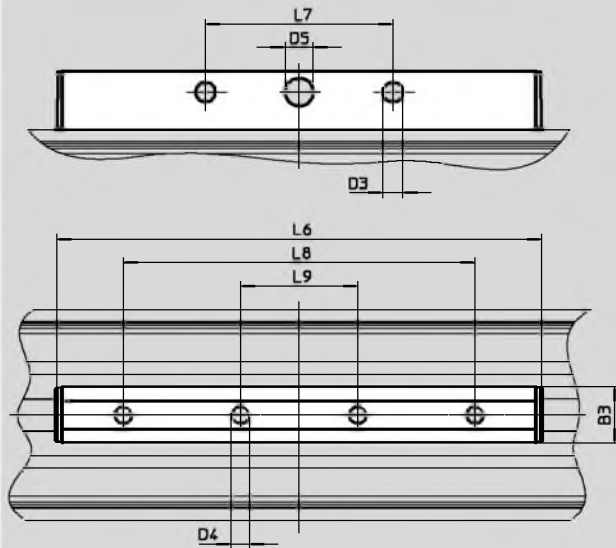

Ø 63

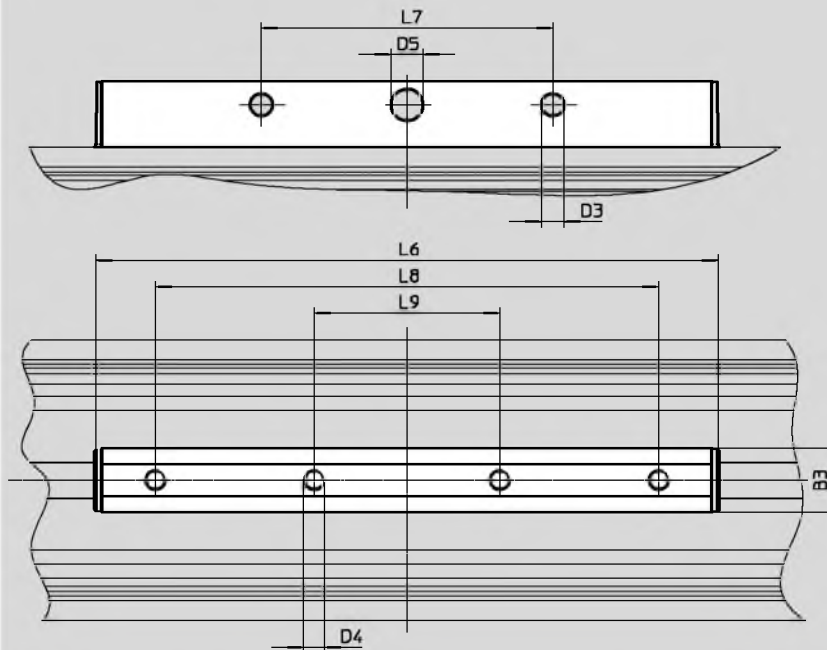

Ø	B3	D3	D4	D5	L6	L7	L8	L9
[mm]	±0.2	Ø +0.2		Ø H7		±0.1	±0.1	±0.1
50	24	8.5	M8	12	206	80	150	50
63	24	8.5	M8	12	234	110	190	70

Linear drives DGC-K

Technical data

Dimensions

GK – Standard piston

Ø 80

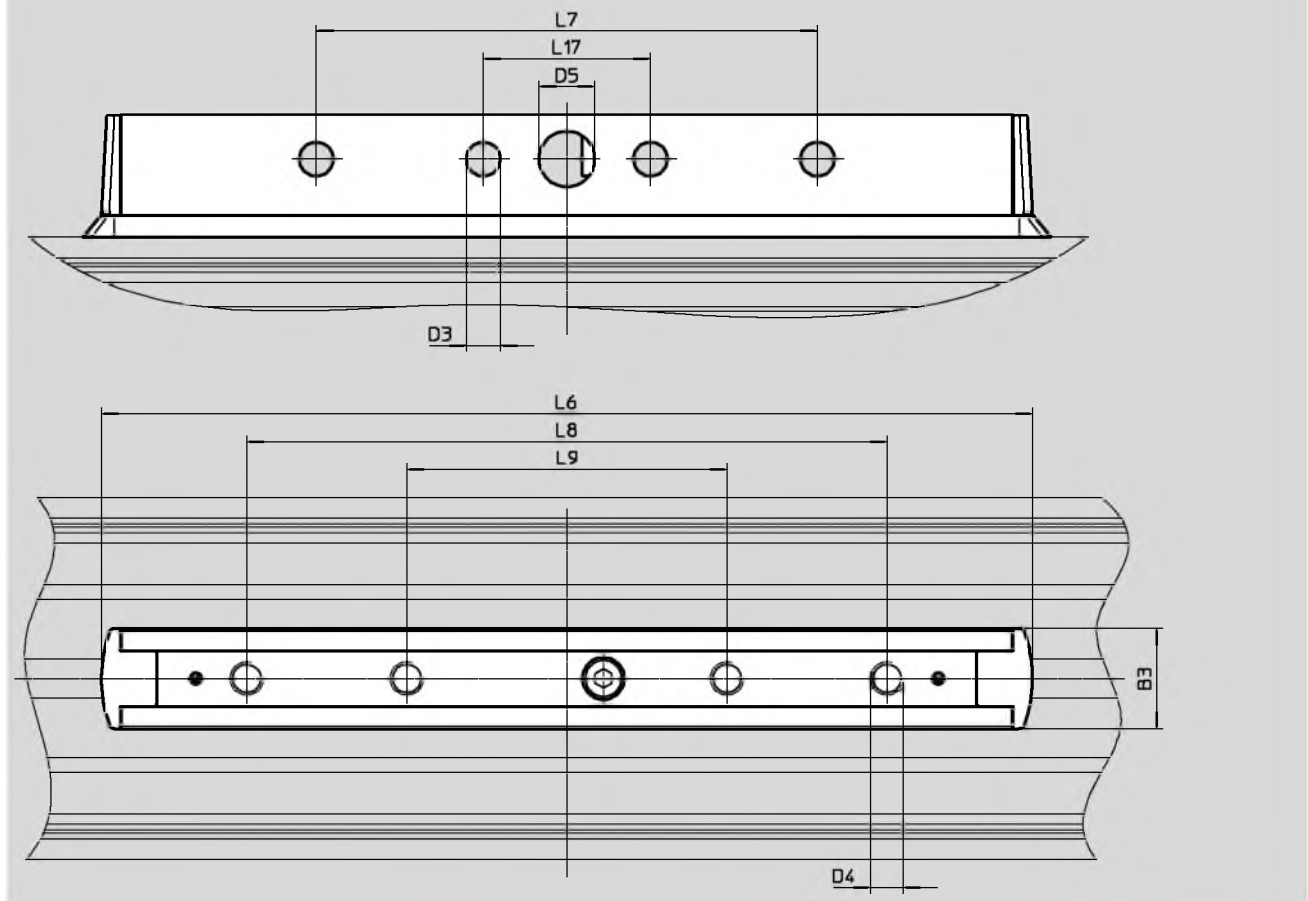

Ø	B3	D3 Ø	D4	D5	L6	L7	L8	L9	L17
[mm]	±0.2	+0.2		H10		±0.15	±0.15	±0.15	±0.15
80	36	12.2	M12	20	334	180	230	115	60

Linear drives DGC-K

Technical data

Dimensions

GV – Extended piston

∅ 18

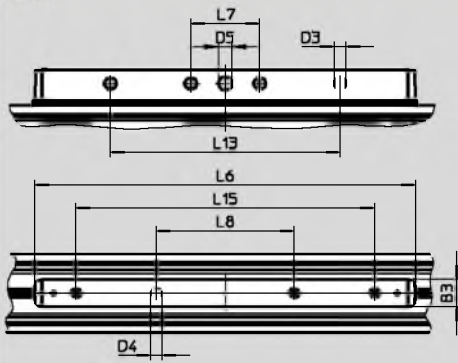

∅ 25

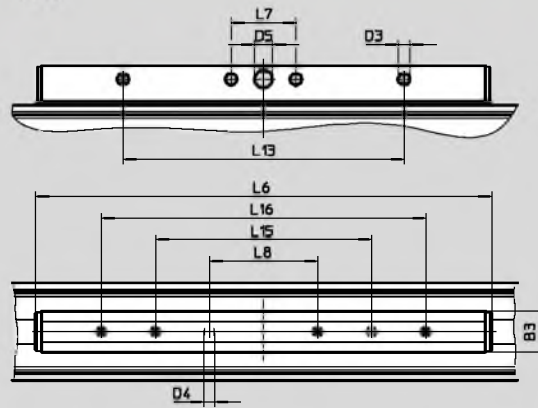

∅ 32

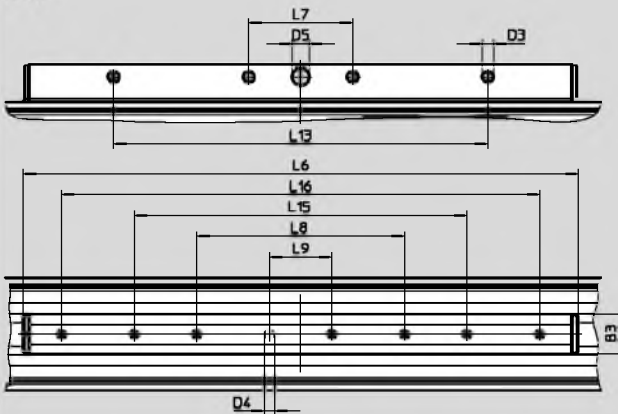

∅ 40

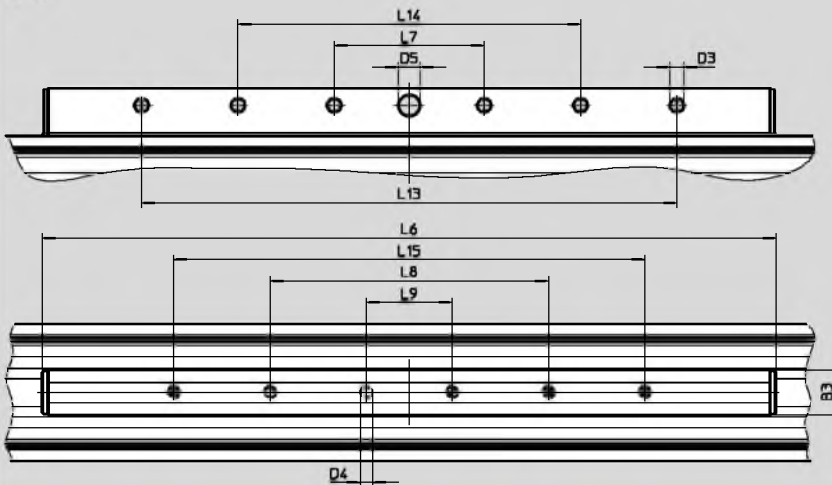

∅	B3	D3	D4	D5	L6	L7	L8	L9	L13	L14	L15	L16
[mm]	±0.2	∅ +0.2		∅ H7		±0.1	±0.1	±0.1	±0.1	±0.1	±0.1	±0.1
18	12	5.2	M5	6	165	30	60	–	100	–	130	–
25	19	5.2	M5	8	209	30	50	–	130	–	100	150
32	19	5.2	M5	8	265	50	100	30	180	–	160	230
40	21	6.5	M6	10	341	70	130	40	160	250	220	–

Linear drives DGC-K

Technical data

Dimensions

GV – Extended piston

Ø 50

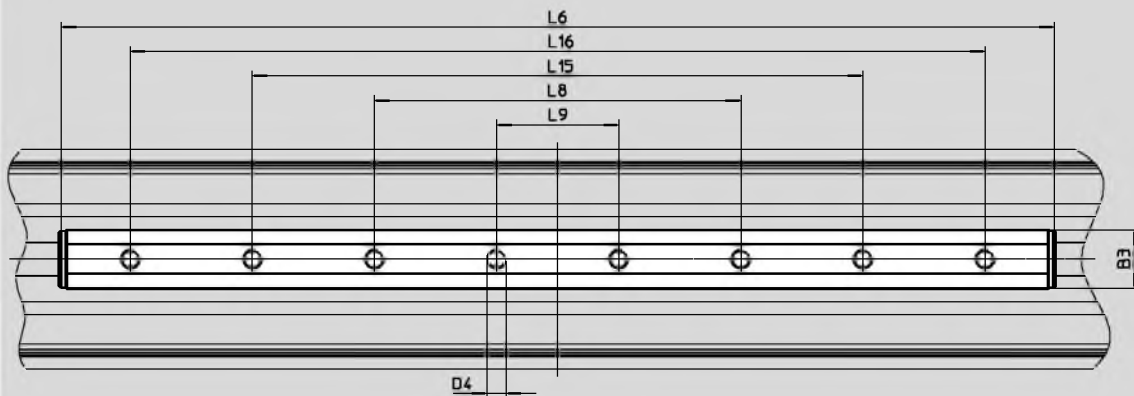
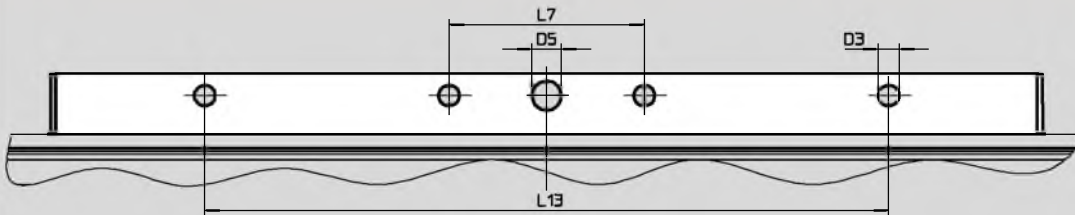

Ø 63

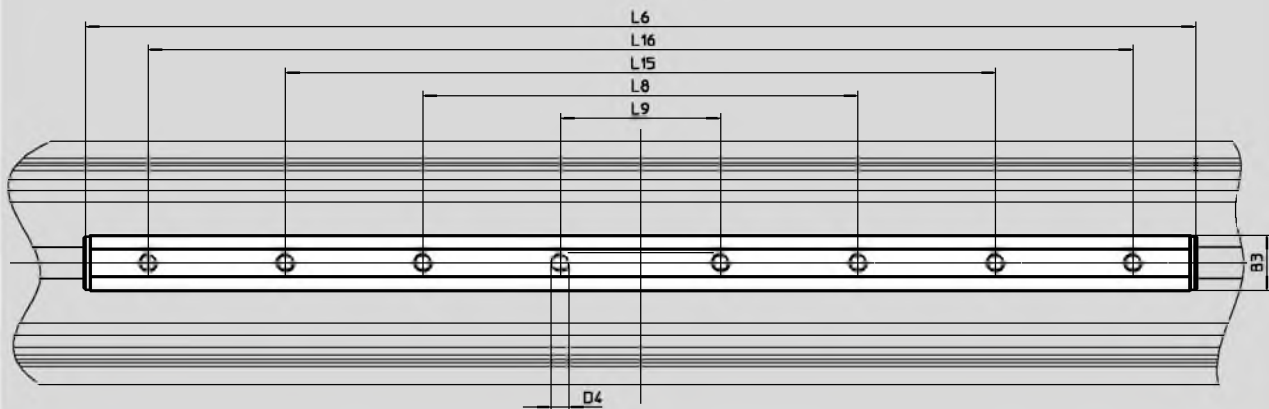
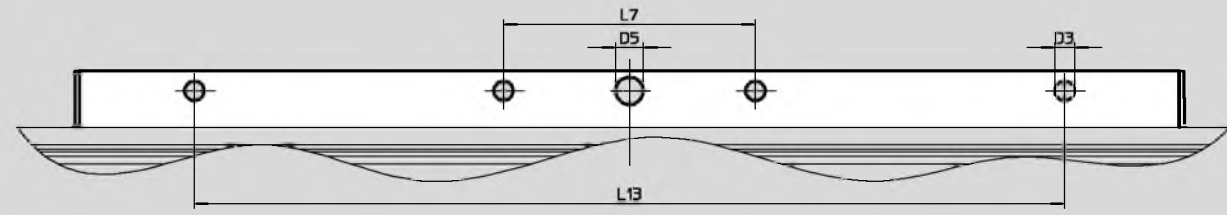

Ø	B3	D3	D4	D5	L6	L7	L8	L9	L13	L15	L16
[mm]	±0.2	Ø +0.2		Ø H7		±0.1	±0.1	±0.1	±0.1	±0.1	±0.1
50	24	8.5	M8	12	406	80	150	50	280	250	350
63	24	8.5	M8	12	484	110	190	70	380	310	430

Linear drives DGC-K

Technical data

Dimensions

Profile barrel

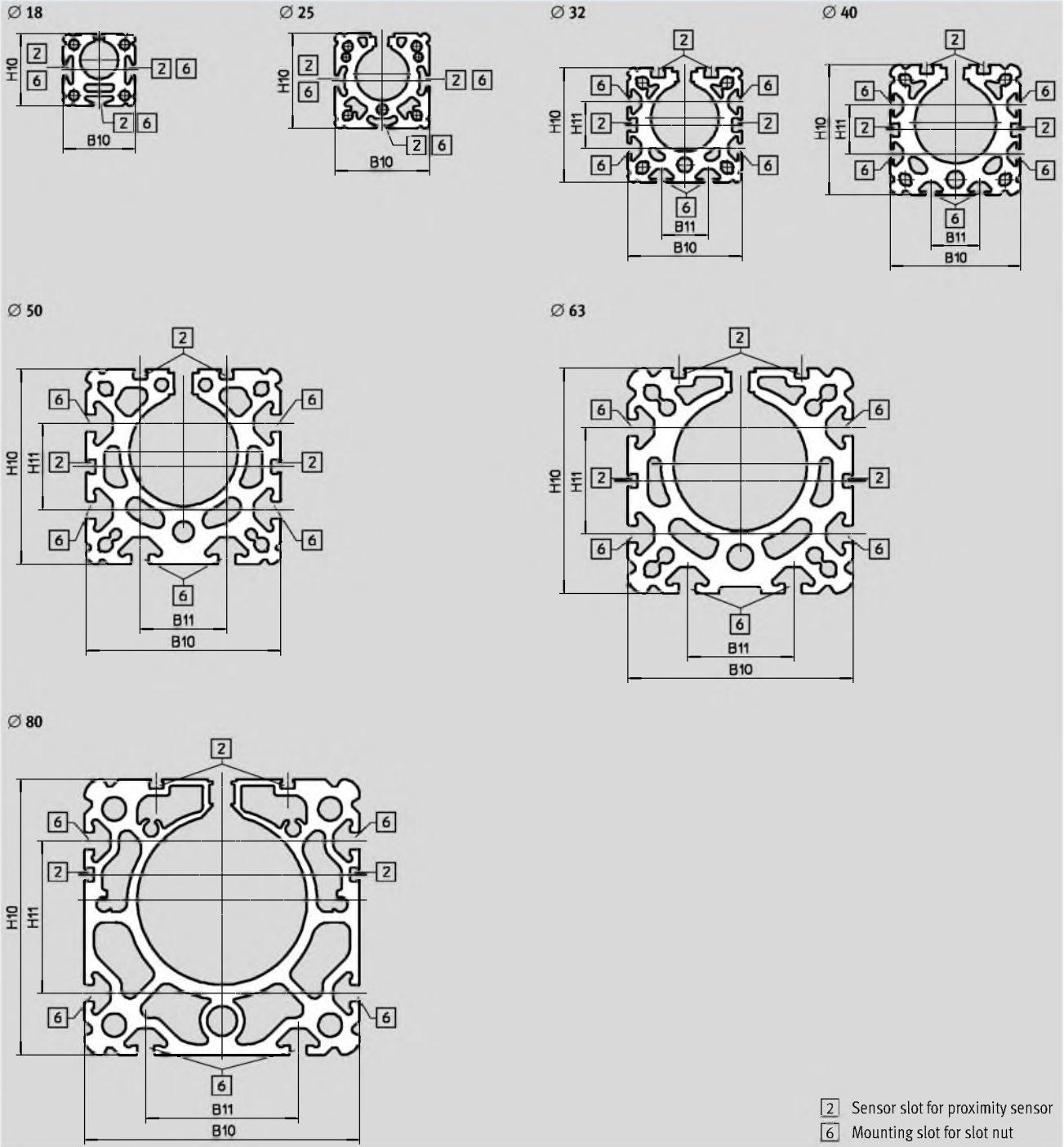

2 Sensor slot for proximity sensor
6 Mounting slot for slot nut

∅ [mm]	B10	B11	H10	H11
18	34	-	34	-
25	45	-	45	-
32	54	22	54	22
40	64	24	64	24
50	90	40	90	40
63	106	50	106	50
80	130	72	130	72

Linear drives DGC-K

Ordering data - Modular products

Order code

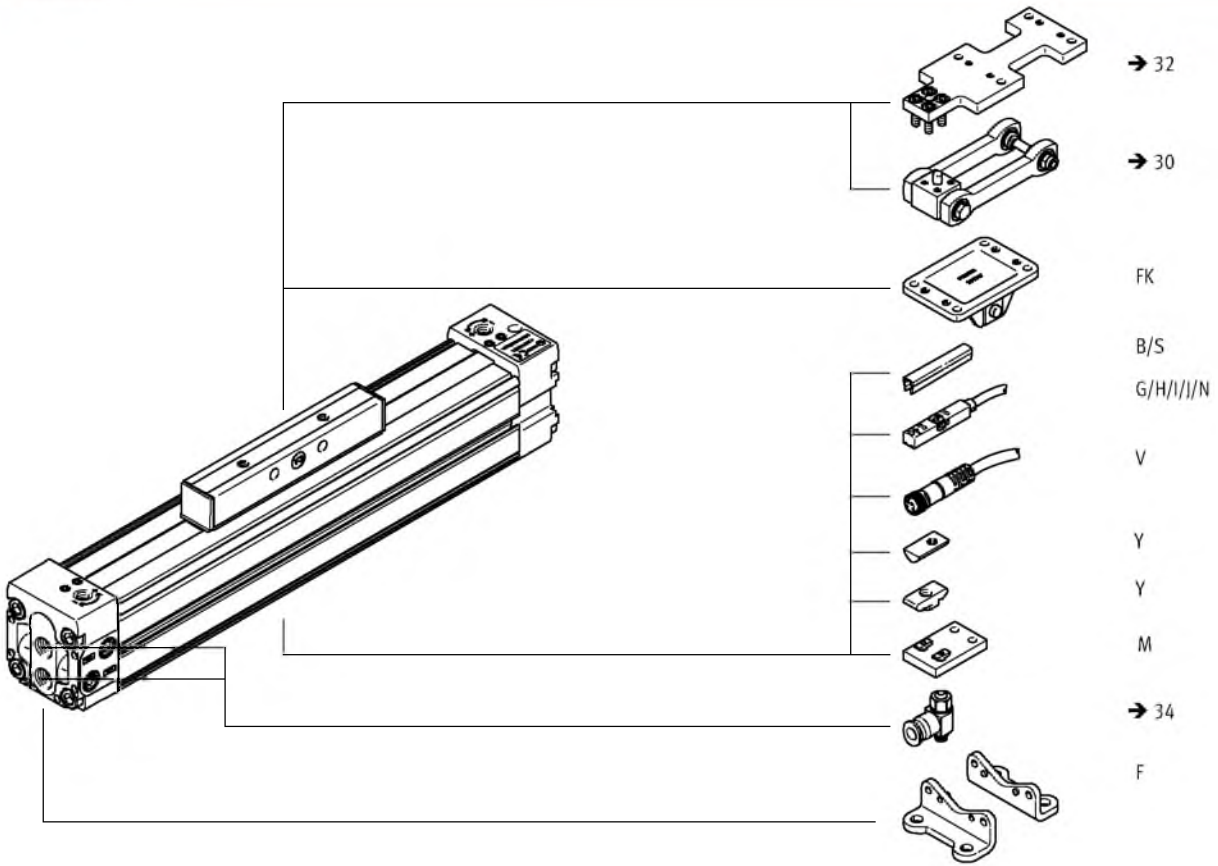

Linear drives DGC-K

Ordering data - Modular product

Ordering table											
Size	18	25	32	40	50	63	80	Condi- tions	Code	Enter code	
M Module No.	1312500	1312501	1312502	1312503	1312504	1312505	1312506				
Function	Linear drive								DGC		DGC
Guide	Compact								-K		-K
Piston Ø [mm]	18	25	32	40	50	63	80		-...		
Stroke [mm]	1 ... 3000	1 ... 8500			1 ... 6000	1 ... 5000	1 ... 3000		-...		
Cushioning	Pneumatic cushioning, adjustable at both ends								-PPV		-PPV
Position sensing	For proximity sensor								-A		-A
Basic design	Standard piston								-GK		
	Extended piston							-	-GV		
Q Compressed air connection	At one end										
	At both ends							3	-D2		
Lubrication	Standard										
	Lubrication approved for use in food applications								-H1		
Moment compensator	Moment compensator coupling								-FK		
EU certification	II 3GD							1	-EX2		
	II 2G							1	-EX3		
O Accessories	Enclosed separately (can be retrofitted)								ZUB-		ZUB-
Foot mounting	1								F		
Central support	1 ... 10								...M		
Slot nut for mounting slot	1 ... 10							2 3	...Y		
Slot cover for mounting slot	-		1 ... 10					...B			
Proximity sensor, N/O contact	2.5 m cable	1 ... 10						...G			
	M8 plug	1 ... 10						...H			
Proximity sensor, N/O contact, contactless, PNP	2.5 m cable	1 ... 10						...I			
	M8 plug	1 ... 10						...J			
Proximity sensor, N/C contact	7.5 m cable	1 ... 10						...N			
Connecting cable	M8, 2.5 m	1 ... 10						...V			
Slot cover for sensor slot	1 ... 10								...S		

- 1 EX2, EX3** Not with proximity sensor G, H, I, J, N or connecting cable V
- 2 Y** For sizes 18 and 25 there is just one slot for mounting and proximity sensor.
- 3 Y + D2** The following applies to sizes 18 and 25: entry "1Y" = delivery quantity of 4 units

- M** Mandatory data
- O** Options

Linear drives DGC-K

Accessories

Foot mounting HP
(order code: F)

Material:
Galvanized steel
Free of copper and PTFE

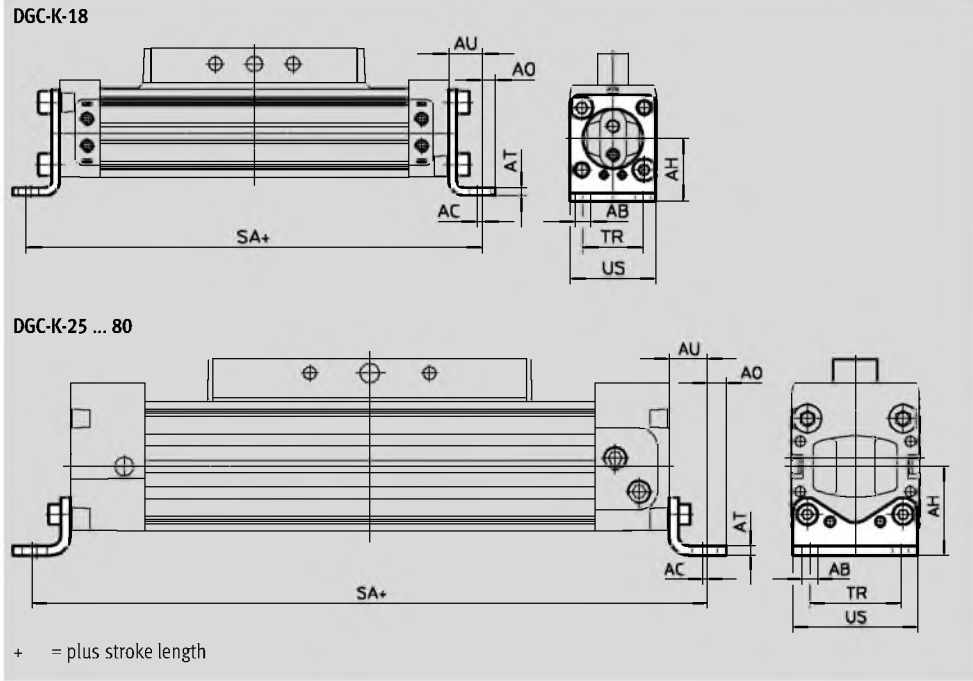

Dimensions and ordering data													
For Ø	AB Ø	AC	AH	AO	AT	AU	SA		TR	US	Weight [g]	Part No.	Type ¹⁾
							GK	GV					
[mm]													
18	5.5	2	24	4.7	3	13.3	176.6	256.6	24	33.2	59	158472	HP-18
25	5.5	2	29.5	6	3	13	226	326	32.5	44	61	150731	HP-25
32	6.6	2	37	7	4	17	284	414	38	52	117	150732	HP-32
40	6.6	2	46	8.5	5	17.5	335	505	45	62	188	150733	HP-40
50	9	3	61	11	6	25	400	600	65	87	243	150734	HP-50
63	11	3	69	13.5	6	28	456	706	75	102	305	150735	HP-63
80	13	3	85	12	8	28	576	-	72	128	620	158453	HP-80

2) Suitable for ATEX areas

Linear drives DGC-K

Accessories

Central support MUP (order code: M)

Material:
Anodised aluminium
Free of copper and PTFE



DGC-K-18/25 with MUP-18/25

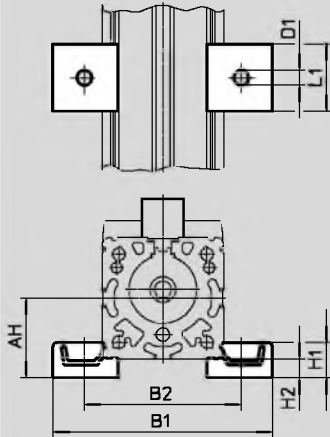

DGC-K-18/25 with MUP-18/25-P
(for mounting on one side)

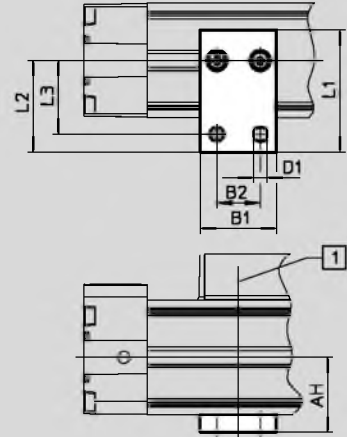

DGC-K-32 ... 80

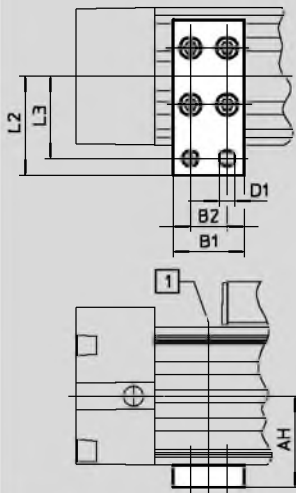

1) Position of the central support along the profile barrel is freely selectable

Dimensions and ordering data												
For \varnothing	AH	B1	B2	D1	H1	H2	L1	L2	L3	Weight	Part No.	Type ²⁾
[mm]				\varnothing						[g]		
18	24	70.5	47	5.5	13	7	25	-	-	33	150736	MUP-18/25
	24	30	17	5.5	-	-	48	36	29	32	1711704	MUP-18/25-P ¹⁾
25	29.5	81	58	5.5	13	7	25	-	-	33	150736	MUP-18/25
	29.5	30	17	5.5	-	-	48	36	29	32	1711704	MUP-18/25-P ¹⁾
32	37	35	22	6.6	-	-	-	41.5	35	89	150737	MUP-32
40	46	35	22	6.6	-	-	-	47	40	126	150738	MUP-40
50	61	50	26	11	-	-	-	70	58	241	150739	MUP-50
63	69	50	26	11	-	-	-	77	65	340	150800	MUP-63
80	85	50	26	11	-	-	-	88	76	590	158455	MUP-80

1) This central support cannot be ordered within the modular product system using Code M.
2) Suitable for ATEX areas

Linear drives DGC-K

Accessories

Moment compensator DARD-S (order code: FK)

Materials:

Bolt: High-alloy steel

Clevis: High-alloy steel

Slip piece: Brass

Retaining ring: Spring steel

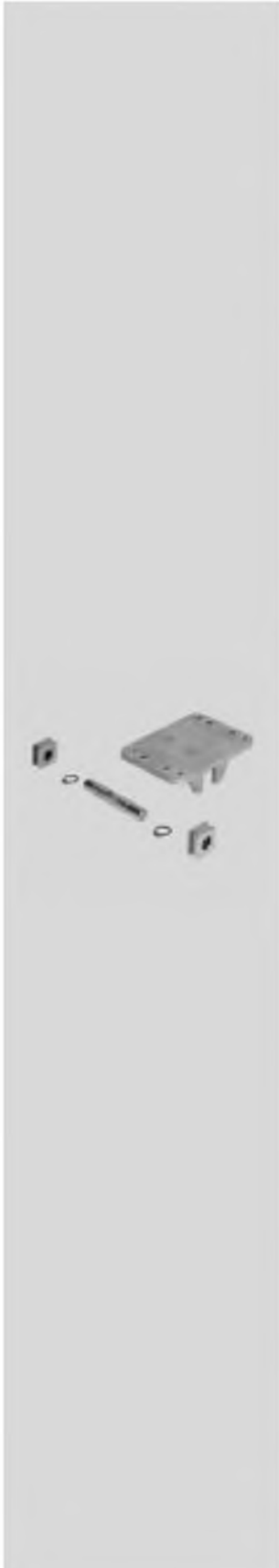

DGC-K-18

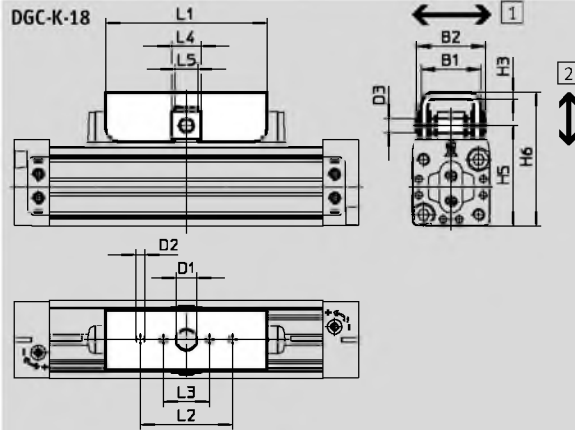

DGC-K-25 ... 40

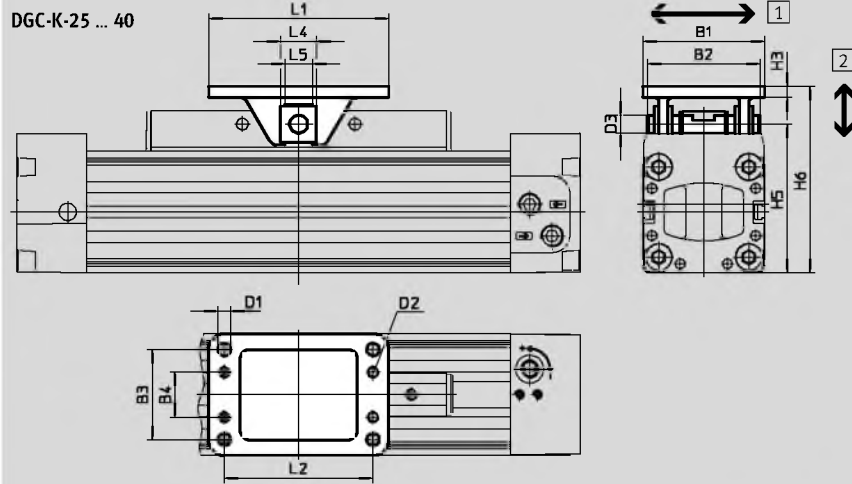

DGC-K-50 ... 80

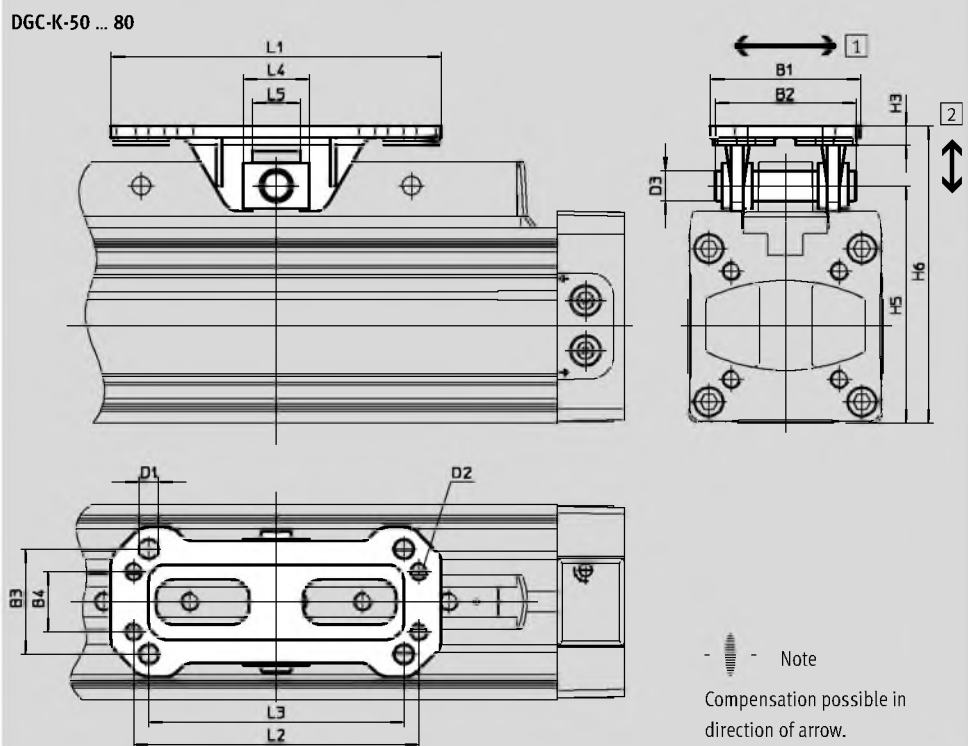

- - Note

The moment compensator DARD-S has the same interface as the moment compensator FKP with the linear drive DGP.

Use moment compensator DARD-M for servopneumatic systems.

- - Note

Compensation possible in direction of arrow.

Linear drives DGC-K

Accessories

Technical data					
For Ø [mm]	Max. offset between linear drive and external guide		Max. permissible load in direction of force [N]	Ambient temperature [°C]	Weight [g]
	1 [mm]	2 [mm]			
18	±1.8	±1.2	550	-20 ... +120	104
25	±2	±2	1100		231
32			1100		231
40			1800		362
50			2500		712
63			2500		712
80	±4	±4	7000		1955

Dimensions and ordering data										
For Ø [mm]	B1	B2	B3	B4	D1 Ø	D2	D3 Ø	H3	H5	H6
18	26	30	-	-	9	M4	6	3	43.8	57.8
25	54	50	40	20	5.5	M5	8	5	57	75
32									66	84
40	58	60	44	24	6.5	M6	10	6	78	99
50	71	63	51	23	9	M8	12	8	106	130
63									122	146
80	100	94	70	40	13	M12	20	13	158	194.5

For Ø [mm]	L1	L2	L3	L4	L5	Part No.	Type
18	70	40	20	13	10.1	8001411	DARD-L1-18-S
25	80	66	-	16	12.1	8001412	DARD-L1-32-S
32						8001412	DARD-L1-32-S
40	90	76	-	18	14.1	8001413	DARD-L1-40-S
50	122	102	-	22	16.1	8001414	DARD-L1-63-S
63						8001414	DARD-L1-63-S
80	220	190	170	44	32.1	8001415	DARD-L1-80-S

Linear drives DGC-K

Accessories

Moment compensator DARD-M

Materials:
Galvanized steel



Ø 18

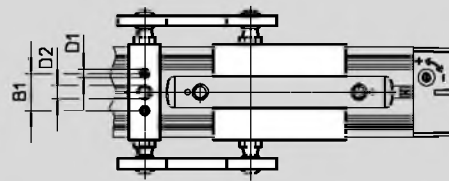
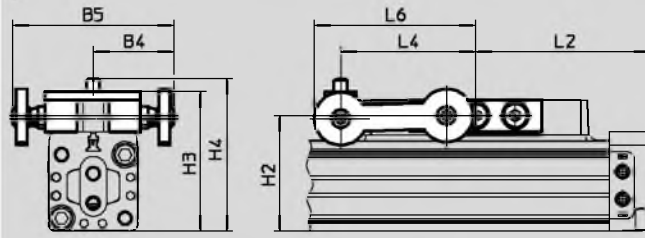

Ø 25 ... 80

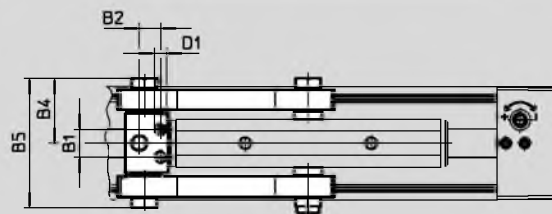
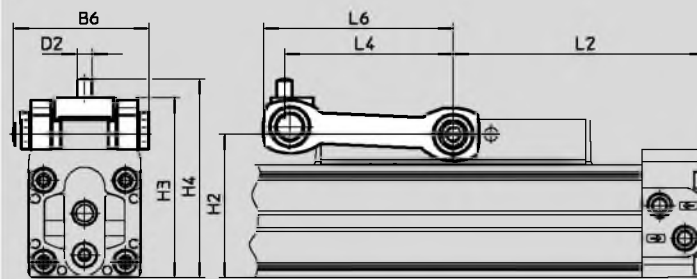

Ø 32 ... 63



Ø 80



Linear drives DGC-K

Accessories

Technical data				
For \varnothing [mm]	Max. offset between linear drive and external guide ¹⁾ [mm]	Max. permissible load in direction of force [N]	Ambient temperature [°C]	Weight [g]
18	±2,5	400	-10 ... +60	94
25		800		240
32		1300		275
40		2000		580
50	±4	3150		960
63		5000		1000
80		7800		2815

1) Laterally and vertically.

Dimensions and ordering data									
For \varnothing [mm]	B1	B2	B3	B4	B5	B6	D1 \varnothing	D2 \varnothing	H2
18	14	-	-	30.5±2.5	61	-	M3x6.2	5	43.8
25	11	8.4	-	25.7±2.5	51.4	54	M5x17	6	57
32	12	6.2	12.4	25.7±2.5	51.4	54	M5x13	6	66
40	18	11	17	36±2.5	72	75.3	M6x16	8	78
50	26	12.6	19	44±4	88	96.4	M8x18	10	106
63	26	12.6	19	44±4	88	96.4	M8x18	10	122
80	36	6	27	61.6±4	123.2	130	M8x26.6	12	158

For \varnothing [mm]	H3	H4	L2	L4	L6 max.	Part No.	Type
18	52.8±2.5	57.8±2.5	75	51	61	2349274	DARD-L1-18-M
25	71.5±2.5	79±2.5	100	67.1	75.5	2349275	DARD-L1-25-M
32	80.5±2.5	88±2.5	125	80.3	91	2349276	DARD-L1-32-M
40	94.5±2.5	104.5±2.5	150	104	117	2349277	DARD-L1-40-M
50	125.5±4	135.5±4	175	124	139	2349278	DARD-L1-50-M
63	142±4	152±4	200	138	153	2349279	DARD-L1-63-M
80	187.5±4	199.5±4	260	182.9	212.5	2349280	DARD-L1-80-M

Linear drives DGC-K

Accessories

Adapter plate DAMF

Materials:
Galvanized steel

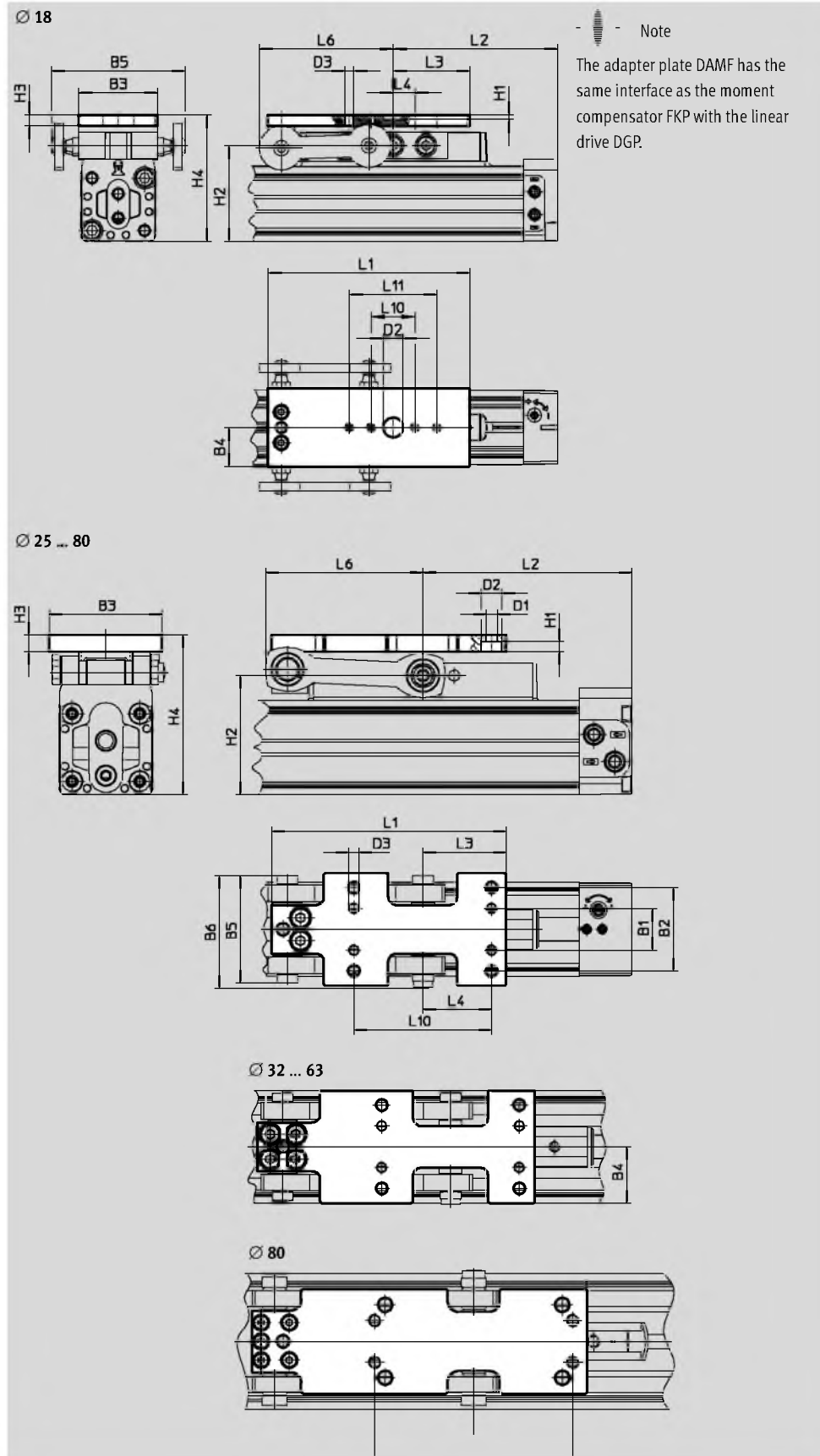

Linear drives DGC-K

Accessories







Dimensions and ordering data								
For Ø	B1	B2	B3	B4	B5	B6	D1 Ø	D2 Ø
[mm]				±2.5				
18	–	–	36	18±2.5	61	–	–	9
25	20	40	54	27±2.5	51.4	54	5.5	10
32	20	40	54	27±2.5	51.4	54	5.5	10
40	24	44	58	29±2.5	72	75.3	6.6	11
50	23	51	71	35±4	88.1	96.4	9	15
63	23	51	71	35±4	88.1	96.4	9	15
80	40	70	100	50±4	123.2	130	13,5	20

For Ø	D3	H1	H2	H3	H4	L1	L2	L3
[mm]								
18	M4	2.1	43.8	5	57.8±2.5	92	75	35
25	M5	5	57	8	75±2.5	112.4	100	40
32	M5	5	66	8	84±2.5	133	125	40.5
40	M6	6	78	10	99±2.5	162	150	45
50	M8	8	106	10	130±4	200	175	61
63	M8	8	122	10	146±4	214	200	61
80	M12	9	158	12	194±4	322.4	260	109

For Ø	L4	L5	L6	L10	L11	Weight	Part No.	Type
[mm]			max.					
18	10	–	61	20	40	127	2349281	DAMF-18-FKP
25	33	–	75.5	66	–	265	2349282	DAMF-25-FKP
32	33	–	91	66	–	308	2349283	DAMF-32-FKP
40	38	–	117	76	–	593	2349284	DAMF-40-FKP
50	51	–	139	102	–	966	2349285	DAMF-50-FKP
63	51	–	153	102	–	1042	2349286	DAMF-63-FKP
80	85	95	212.5	170	190	2817	2349287	DAMF-80-FKP

Linear drives DGC-K

Accessories



Ordering data						
	For Ø	Description	Order code	Part No.	Type	PU ¹⁾
Slot nut ABAN/NST ²⁾ Technical data → Internet: hmbn						
	18, 25	For mounting slot	Y	8003032	ABAN-1M4-5	4
	18, 25	<ul style="list-style-type: none"> For mounting slot Piston Ø 18 and 25: cannot be used with DGC-...-D2 (compressed air connection at both ends) 		526091	NST-HMV-M4	10
	32, 40 50, 63, 80	For mounting slot		150914	NST-5-M5	1
			150915	NST-8-M6		
Slot cover ABP ²⁾ Technical data → Internet: abp						
	32, 40 50, 63, 80	For mounting slot Every 0.5 m	B	151681	ABP-5	2
				151682	ABP-8	
	18, 25, 32, 40, 50, 63, 80	For sensor slot Every 0.5 m	S	563360	ABP-5-S1	2
One-way flow control valve GRLA Technical data → Internet: grla						
	18 25, 32 40, 50 63 80	Metal design	–	193137	GRLA-M5-QS-3-D	1
				193138	GRLA-M5-QS-4-D	
				193142	GRLA-1/8-QS-3-D	
				193143	GRLA-1/8-QS-4-D	
				193144	GRLA-1/8-QS-6-D	
				193145	GRLA-1/8-QS-8-D	
				193146	GRLA-1/4-QS-6-D	
				193147	GRLA-1/4-QS-8-D	
				193148	GRLA-1/4-QS-10-D	
				193149	GRLA-3/8-QS-6-D	
				193150	GRLA-3/8-QS-8-D	
				193151	GRLA-3/8-QS-10-D	
				193152	GRLA-1/2-QS-12-D	

1) Packaging unit

2) Suitable for ATEX areas



 Note

When using the variant DGC-K-...-D2 (supply port at both ends), only proximity sensors that are inserted in the slot from above can be used.

Ordering data – Proximity sensors for T-slot, magneto-resistive Technical data → Internet: smt						
	Type of mounting	Switching output	Electrical connection	Cable length [m]	Part No.	Type
N/O contact						
	Insertable in the slot from above, flush with the cylinder profile, short design	PNP	Cable, 3-wire	2.5	574335	SMT-8M-A-PS-24V-E-2,5-OE
			Plug M8x1, 3-pin	0.3	574334	SMT-8M-A-PS-24V-E-0,3-M8D
		NPN	Cable, 3-wire	2.5	574337	SMT-8M-A-PS-24V-E-0,3-M12
			Plug M8x1, 3-pin	0.3	574339	SMT-8M-A-NS-24V-E-0,3-M8D
N/C contact						
	Insertable in the slot from above, flush with the cylinder profile, short design	PNP	Cable, 3-wire	7.5	574340	SMT-8M-A-PO-24V-E-7,5-OE



Linear drives DGC-K

Accessories

Ordering data – Proximity sensors for T-slot, magnetic reed						Technical data → Internet: sme	
	Type of mounting	Switching output	Electrical connection	Cable length [m]	Part No.	Type	
N/O contact							
	Insertable in the slot from above, flush with the cylinder profile	Contacting	Cable, 3-wire	2.5	543862	SME-8M-DS-24V-K-2,5-OE	
				5.0	543863	SME-8M-DS-24V-K-5,0-OE	
			Plug M8x1, 3-pin	2.5	543872	SME-8M-ZS-24V-K-2,5-OE	
				0.3	543861	SME-8M-DS-24V-K-0,3-M8D	
N/C contact							
	Insertable in the slot from above, flush with the cylinder profile	Contacting	Cable, 3-wire	7.5	546799	SME-8M-DO-24V-K-7,5-OE	

Ordering data – Proximity sensors for T-slot, magneto-resistive for ATEX areas						Technical data → Internet: smt		
	Type of mounting	ATEX category		Switch output	Electrical connection	Cable length [m]	Part No.	Type
		Gas	Dust					
N/O contact								
	Insertable in the slot from above, flush with cylinder profile, short design	II 3G	II 3D	PNP	Plug M8x1, 3-wire	0,3	574342	SMT-8M-A-PS-24V-E-0,3-M8D-EX2

Ordering data – Safety clip for ATEX areas					
	Description	Size	Part No.	Type	
N/O contact					
	<ul style="list-style-type: none"> Protects "equipment that is not intrinsically safe" against simple disconnection, here the plug of the proximity sensor SMT and connecting cable NEBU ATEX-category: Gas: II 3G / Dust: II 3D 	Plug M8x1	548067	NEAU-M8-GD	

Ordering data – Connecting cables				Technical data → Internet: nebu	
	Electrical connection, left	Electrical connection, right	Cable length [m]	Part No.	Type
	Straight socket, M8x1, 3-pin	Cable, open end, 3-wire	2.5	541333	NEBU-M8G3-K-2.5-LE3
			5	541334	NEBU-M8G3-K-5-LE3
	Straight socket, M12x1, 5-pin	Cable, open end, 3-wire	2.5	541363	NEBU-M12G5-K-2.5-LE3
			5	541364	NEBU-M12G5-K-5-LE3
	Angled socket, M8x1, 3-pin	Cable, open end, 3-wire	2.5	541338	NEBU-M8W3-K-2.5-LE3
			5	541341	NEBU-M8W3-K-5-LE3
	Angled socket, M12x1, 5-pin	Cable, open end, 3-wire	2.5	541367	NEBU-M12W5-K-2.5-LE3
			5	541370	NEBU-M12W5-K-5-LE3

(8182)63-90-72
+7(7172)727-132
(4722)40-23-64
(4832)59-03-52
(423)249-28-31
(844)278-03-48
(8172)26-41-59
(473)204-51-73
(343)384-55-89
(4932)77-34-06
(3412)26-03-58
(843)206-01-48

(4012)72-03-81
(4842)92-23-67
(3842)65-04-62
(8332)68-02-04
(861)203-40-90
(391)204-63-61
(4712)77-13-04
(4742)52-20-81
(3519)55-03-13
(495)268-04-70
(8152)59-64-93
(8552)20-53-41

(831)429-08-12
(3843)20-46-81
(383)227-86-73
(4862)44-53-42
(3532)37-68-04
(8412)22-31-16
(342)205-81-47
- - (863)308-18-15
(4912)46-61-64
(846)206-03-16
- (812)309-46-40
(845)249-38-78

(4812)29-41-54
(862)225-72-31
(8652)20-65-13
(4822)63-31-35
(3822)98-41-53
(4872)74-02-29
(3452)66-21-18
(8422)24-23-59
(347)229-48-12
(351)202-03-61
(8202)49-02-64
(4852)69-52-93