

# ERMO

:

(8182)63-90-72  
+7(7172)727-132  
(4722)40-23-64  
(4832)59-03-52  
(423)249-28-31  
(844)278-03-48  
(8172)26-41-59  
(473)204-51-73  
(343)384-55-89  
(4932)77-34-06  
(3412)26-03-58  
(843)206-01-48

(4012)72-03-81  
(4842)92-23-67  
(3842)65-04-62  
(8332)68-02-04  
(861)203-40-90  
(391)204-63-61  
(4712)77-13-04  
(4742)52-20-81  
(3519)55-03-13  
(495)268-04-70  
(8152)59-64-93  
(8552)20-53-41

(831)429-08-12  
(3843)20-46-81  
(383)227-86-73  
(4862)44-53-42  
(3532)37-68-04  
(8412)22-31-16  
(342)205-81-47  
- - (863)308-18-15  
(4912)46-61-64  
(846)206-03-16  
- (812)309-46-40  
(845)249-38-78

(4812)29-41 -54  
(862)225-72-31  
(8652)20-65-13  
(4822)63-31-35  
(3822)98-41-53  
(4872)74-02-29  
(3452)66-21 -18  
(8422)24-23-59  
(347)229-48-12  
(351)202-03-61  
(8202)49-02-64  
(4852)69-52-93

# Rotary drives ERMO, electric

Key features

## At a glance

### General

- Electric rotary drive with stepper motor and integrated gear unit
- ServoLite – closed-loop operation with encoder
- Heavy-duty bearing for high forces and torques
- Backlash-free pre-stressed rotating plate with very good axial eccentricity and concentricity properties
- Optional holding brake
- Hollow shaft for energy throughfeed for attachments
- Quick and accurate installation

### Range of applications

- Rotating and positioning parts
- Simple rotary indexing table applications
- As a rotary axis in multi-axis applications

## The technology in detail

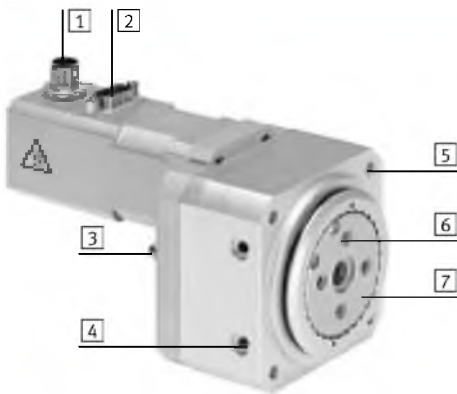

- 1 Encoder connection
- 2 Motor connection
- 3 Proximity sensor for homing or position sensing
- 4 Thread/centring holes for mounting
- 5 Thread for mounting
- 6 Thread/centring holes for attachments
- 7 Rotating plate

## Optimised Motion Series (OMS) – Package solution with motor and motor controller

A package that makes positioning easier than ever before. The Optimised Motion Series is as easy to handle as a pneumatic cylinder, but with the functionality of an electric drive.



### Simple choice

- Easy sizing and selection using cycle time charts
- No specialist knowledge of electric drive technology required

### Ordering and logistics

- All the necessary component parts with a single part number
- Motors mounted on rotary drive

### Quick to configure

- Parameterisation and commissioning via web server/browser
- Parameterise up to 7 freely definable positions directly on the PC



## For simple positioning tasks

Rotary drive ERMO



Controller CMMO

→ Internet: [cmmo](http://cmmo)



# Rotary drives ERMO, electric

Key features

## Mounting options

At the side

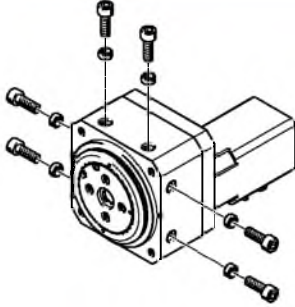

From the front/rear

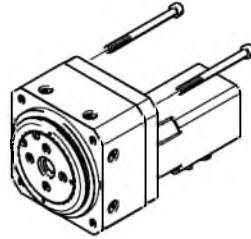

## Motor attachment variants

Top (standard)

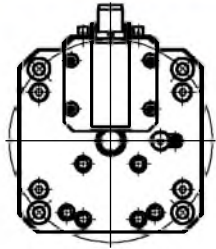

Left (feature L)

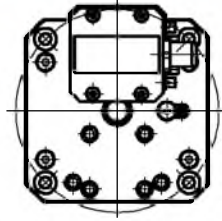

Right (feature R)

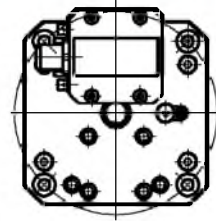

# Rotary drives ERMO, electric

Key features

## Possible combinations within the Optimised Motion Series (OMS)

Electric cylinder EPCO on toothed belt axis ELGR

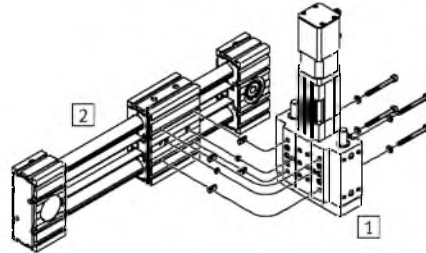
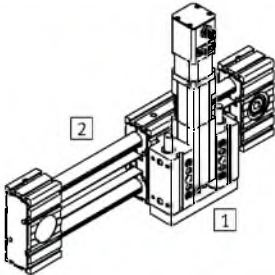

Size		Accessories			
1	2	Slot nut	Centring sleeve	Screw	Washer
EPCO	ELGR				
16	35	NST-3-M3 (x4)	ZBH-7 (x2)	M3x10 (x4)	-
25	45	NST-5-M5 (x4)	ZBH-7 (x2)	M5x50 (x4)	DIN125-A5.3 (x4)
40	55	NST-5-M5 (x4)	ZBH-7 (x2)	M5x65 (x4)	DIN125-A5.3 (x4)

## Rotary drive ERMO on electric cylinder EPCO

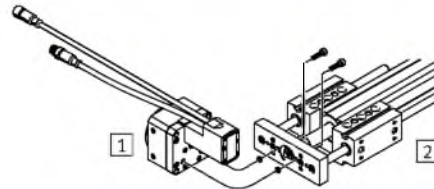
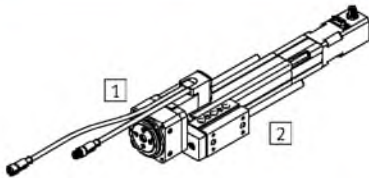

Size		Accessories	
1	2	Centring sleeve	Screw
ERMO	EPCO		
12	16	ZBH-7 (x2)	M4x16 (x2)
16	25	ZBH-7 (x2)	M5x18 (x2)
25	40	ZBH-7 (x2)	M5x20 (x2)

## Rotary drive ERMO on mini slide DGSL

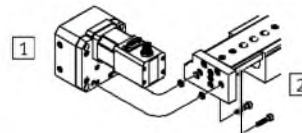
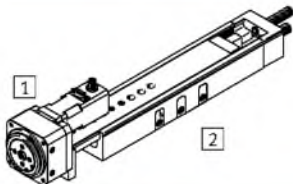

Size		Accessories	
1	2	Centring sleeve	Screw
ERMO	DGSL		
12	12	ZBH-7 (x2)	M4x18 (x2)
25	20	ZBH-9-7 (x2)	M5x22 (x2)
25	25	ZBH-9-7 (x2)	M5x22 (x2)

## Rotary drive ERMO on mini slide EGSL

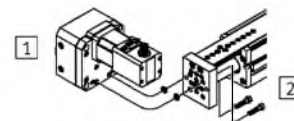
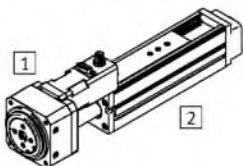

Size		Accessories	
1	2	Centring sleeve	Screw
ERMO	EGSL		
12	35	ZBH-7 (x2)	M4x12 (x2)
16	45	ZBH-7 (x2)	M5x12 (x2)
25	55	ZBH-7 (x2)	M5x14 (x2)
32	55	ZBH-7 (x2)	M5x14 (x2)

# Rotary drives ERMO, electric

Key features

## Possible combinations within the Optimised Motion Series (OMS)

Electric cylinder EPCO on electric cylinder EPCO, horizontal

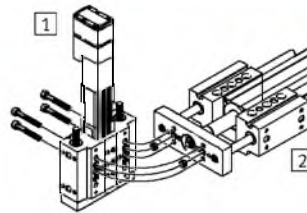
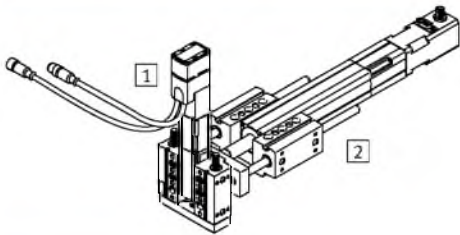

Size		Accessories	
1 EPCO	2 EPCO	Centring sleeve	Screw
16	25	ZBH-9 (x2)	M6x40 (x4)
25	40	ZBH-9 (x2)	M6x55 (x4)

Electric cylinder EPCO on electric cylinder EPCO, vertical

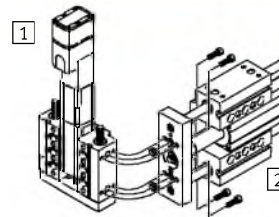
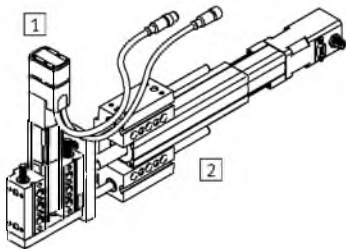

Size		Accessories	
1 EPCO	2 EPCO	Centring sleeve	Screw
16	25	ZBH-9 (x2)	M5x18 (x4)
25	40	ZBH-9 (x2)	M5x22 (x4)

Mini slide DGSL on electric cylinder EPCO

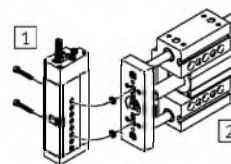
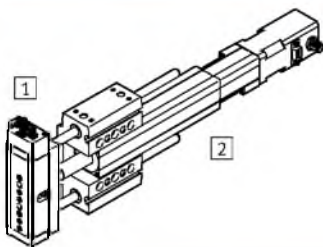

Size		Accessories	
1 DGSL	2 EPCO	Centring sleeve	Screw
8 (40mm) <sup>1)</sup>	16	ZBV-9-7 (x2)	M4x16 (x2)
10 (30mm) <sup>1)</sup>	25	ZBV-9-7 (x2)	M4x20 (x2)
12 (40mm) <sup>1)</sup>	40	ZBV-9-7 (x2)	M5x20 (x2)

1) Minimum stroke

# Rotary drives ERMO, electric

Type codes

ERMO - 16 - ST - E B - + 5E + C5 DIO P

## Type

ERMO	Rotary drive
------	--------------

## Size

## Motor type

ST	Stepper motor
----	---------------

## Measuring unit

E	Encoder
---	---------

## Brake

-	None
B	With brake

## Cable outlet direction

-	Top (standard)
L	Left
R	Right

## Connecting cable to motor controller

-	None
1.5E	1.5 m, straight plug connector
2.5E	2.5 m, straight plug connector
5E	5 m, straight plug connector
7E	7 m, straight plug connector
10E	10 m, straight plug connector
1.5EA	1.5 m, angled plug connector
2.5EA	2.5 m, angled plug connector
5EA	5 m, angled plug connector
7EA	7 m, angled plug connector
10EA	10 m, angled plug connector

## Controller type

C5	CMMO, 5 A
----	-----------

## Bus protocol/activation

-	None
DIO	Digital I/O interface
LK	IO-Link

## Switching input/output

-	None
N	NPN
P	PNP

# Rotary drives ERMO, electric

Peripherals overview

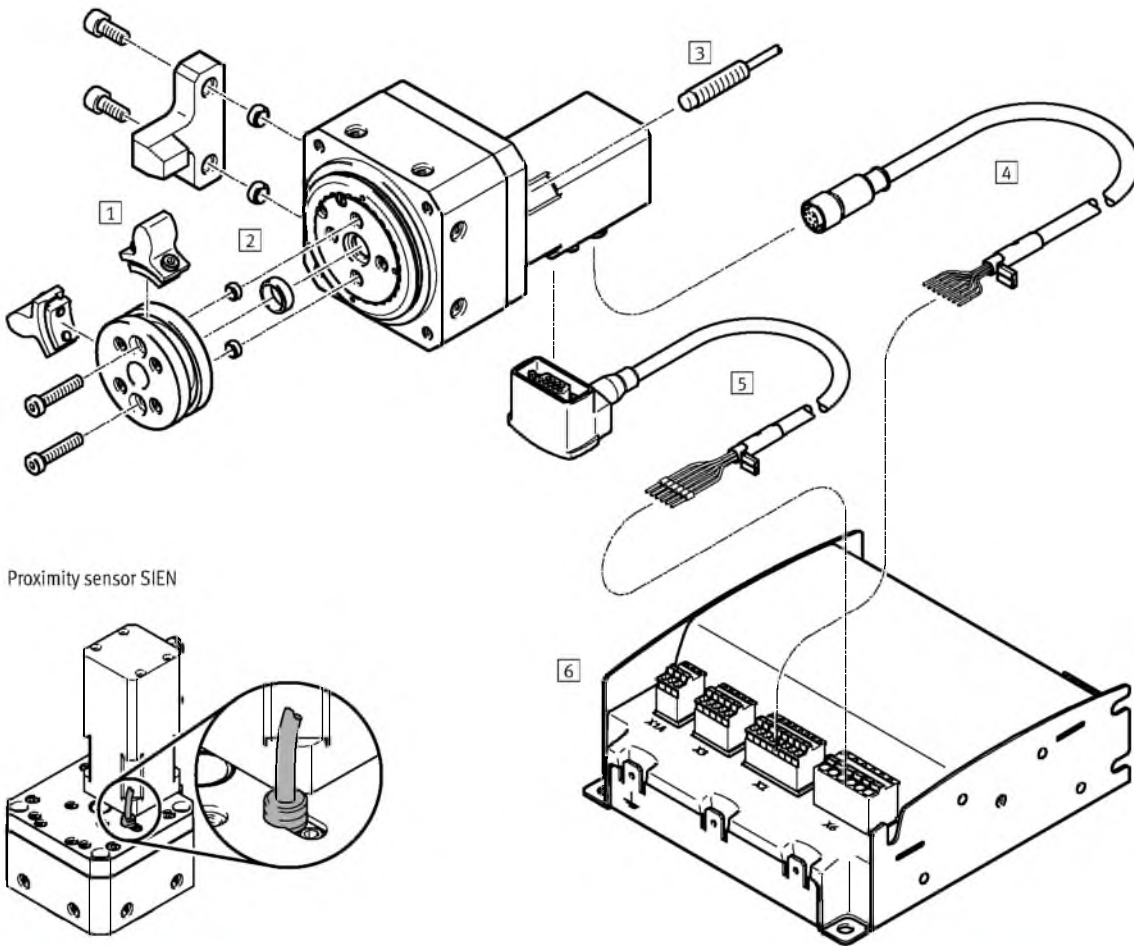

Proximity sensor SIEN

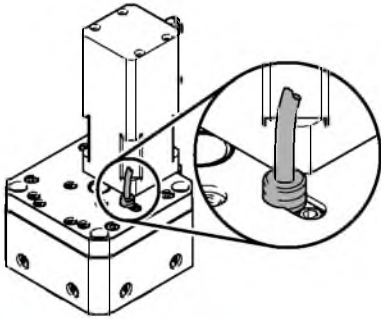

Accessories			
Type/order code	Description		→ Page/Internet
1 Stop kit EADP	<ul style="list-style-type: none"> <li>• For homing to the end position</li> <li>• As end stop for rotary drives with no brake</li> <li>• For safety functions</li> </ul>		20
2 Centring sleeve ZBH	<ul style="list-style-type: none"> <li>• For centring attachments</li> <li>• For centring the rotary drive</li> </ul>		21
3 Proximity sensor SIEN	For homing or position sensing		21
4 Encoder cable NEBM	For connecting the encoder and controller		22
5 Motor cable NEBM	For connecting the motor and controller		22
6 Motor controller CMMO	For positioning the rotary drive		22

# Rotary drives ERMO, electric

Technical data

Size

12, 16, 25, 32



General technical data					
Size		12	16	25	32
Design		Electromechanical rotary drive with integrated gear unit			
Angle of rotation		Infinite			
Repetition accuracy <sup>1)</sup>	[°]	±0.05	±0.05	±0.05	±0.1
Torsional backlash <sup>1)</sup>	[°]	0.2			
Positioning time		→ 10			
Gear ratio		9:1			7:1
Step angle with full step	[°]	1.8 ±5%			
Type of mounting		Via internal thread			
Mounting position		Any			
Product weight					
Without brake	[g]	475	900	1350	2200
With brake	[g]	–	960	1500	2380

1) Without payload in new condition

Mechanical data					
Size		12	16	25	32
Nominal torque <sup>1)</sup>	[Nm]	0.15	0.8	2.5	5
Holding torque	[Nm]	0.33	0.81	4	7
Nominal rotational speed	[rpm]	100	100	66	50
Max. speed	[rpm]	200	200	150	100
Permissible mass moment of inertia	[kgm <sup>2</sup> x10 <sup>-4</sup> ]	3	13	65	164
Mass moment of inertia J <sub>o</sub>	[kgm <sup>2</sup> x10 <sup>-4</sup> ]	0.0079	0.0383	0.114	0.39
Max. impact energy	[Jx10 <sup>-4</sup> ]	0.2	0.7	1.6	2.9

1) Theoretical torque at nominal rotary speed → 10



# Rotary drives ERMO, electric

Technical data

Electrical data					
Size		12	16	25	32
<b>Motor</b>					
Nominal operating voltage	[V DC]	24			
Nominal current	[A]	0.8	1.4	3	4.2
Duty cycle	[%]	100			
<b>Brake</b>					
Nominal voltage	[V DC]	-		24	
Rated output	[W]	-		8	
Holding torque	[Nm]	-		1	2.5
Mass moment of inertia	[kgm <sup>2</sup> x10 <sup>-4</sup> ]	-		0.69	1.3
<b>Encoder</b>					
Rotary position encoder		Incremental			
Rotary position encoder measuring principle		Opto-electrical			
Pulses/revolution	[1/rev]	500			
Interface		RS422, TTL, AB channel + zero index			
Operating voltage	[V DC]	5			
Insulation protection class		B (130 °C)			

Operating and environmental conditions		
Ambient temperature	[°C]	0 ... +50
Storage temperature	[°C]	-20 ... +60
Degree of protection		IP40
Relative air humidity	[%]	0 ... 85 (non-condensing)
Corrosion resistance class CRC <sup>1)</sup>		1
CE marking (see declaration of conformity)		To EU EMC Directive <sup>2)</sup>
Approval certificate		RCM trademark

## Materials

Sectional view

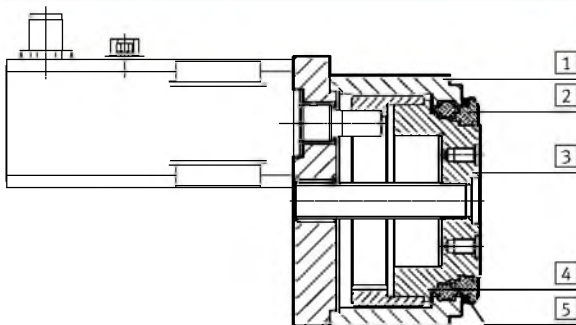

Rotary drive		
1	Housing	Anodised wrought aluminium alloy
2	Clamping ring	Anodised wrought aluminium alloy
3	Rotating plate	Anodised wrought aluminium alloy
4	Ball bearing	Rolled steel
5	Sealing ring	NBR
Note on materials		RoHS compliant
		Contains paint-wetting impairment substances

# Rotary drives ERMO, electric

Technical data

## Torque M as a function of speed n

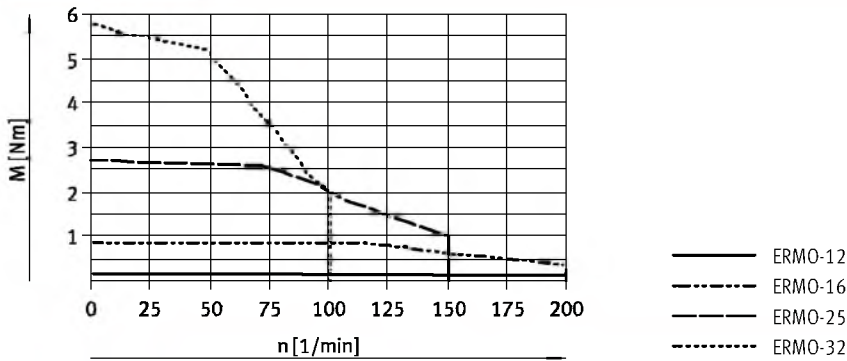

## Positioning time t as a function of angle of rotation $\alpha$

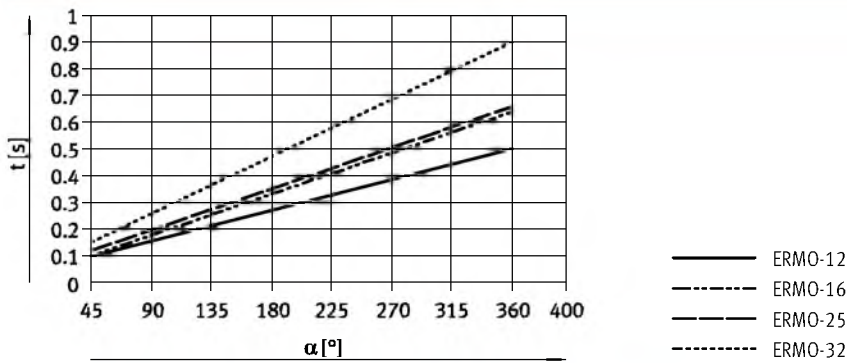

## Axial eccentricity and concentricity

### Axial eccentricity

Measured on the surface of the rotating plate at the plate edge, in new condition.

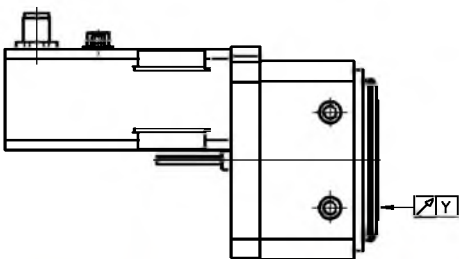

### Concentricity

Measured at the centring hole of the rotating plate, in new condition.

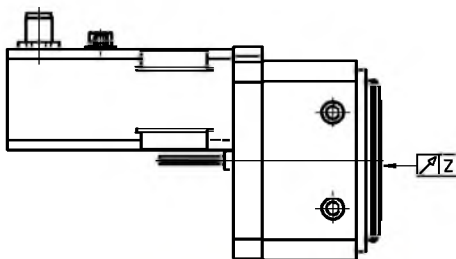

Size		12	16	25	32
Axial eccentricity Y	[mm]	<0.02	<0.02	<0.02	<0.04
Concentricity Z	[mm]	<0.02	<0.02	<0.02	<0.04

# Rotary drives ERMO, electric

Technical data

Max. permissible axial and radial force $F_x/F_z$					
Size		12	16	25	32
Static					
Axial force $F_x$	[N]	500	600	700	800
Radial force $F_z$	[N]	500	750	1200	2000
Dynamic					
Axial force $F_x$	[N]	180	290	350	450
Radial force $F_z$	[N]	200	300	450	550

Max. dynamic axial force  $F_x$  as a function of lever arm  $l$

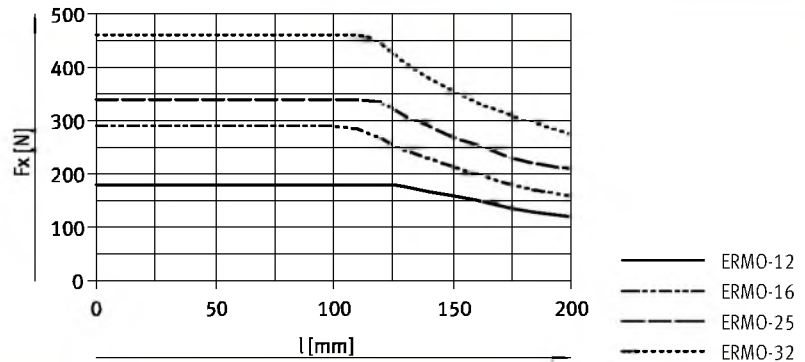
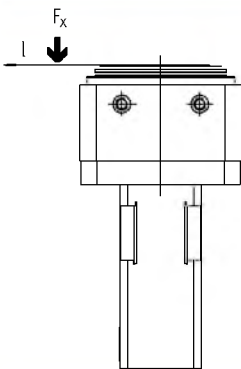

Max. dynamic radial force  $F_z$  as a function of lever arm  $l$

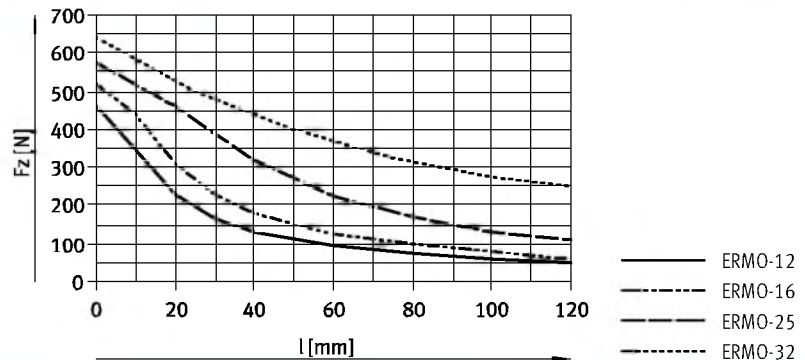
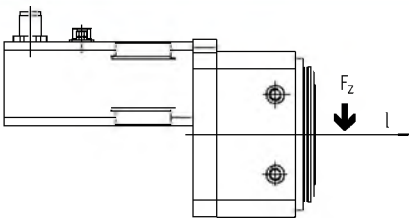

## Pin allocation

Motor

ERMO-12/-16

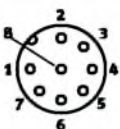

ERMO-25/-32

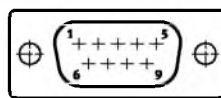

Encoder

ERMO-12/-16/-25/-32

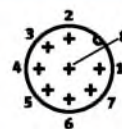

PIN	Function
1	String A
2	String A/
3	String B
4	String B/
5	n.c.
6	n.c.
7	Brake +24 V DC <sup>1)</sup>
8	Brake GND <sup>1)</sup>
-	-

PIN	Function
1	String A
2	String A/
3	String B
4	String B/
5	n.c.
6	n.c.
7	Brake +24 V DC <sup>1)</sup>
8	Brake GND <sup>1)</sup>
9	n.c.

PIN	Function
1	Signal trace A
2	Signal trace A/
3	Signal trace B
4	Signal trace B/
5	GND encoder
6	Signal trace N
7	Signal trace N/
8	VCC auxiliary supply +5 V
GND	Shield on plug housing

1) Only on motors with brake.

# Rotary drives ERMO, electric

Technical data

## Dimensions

Size 12

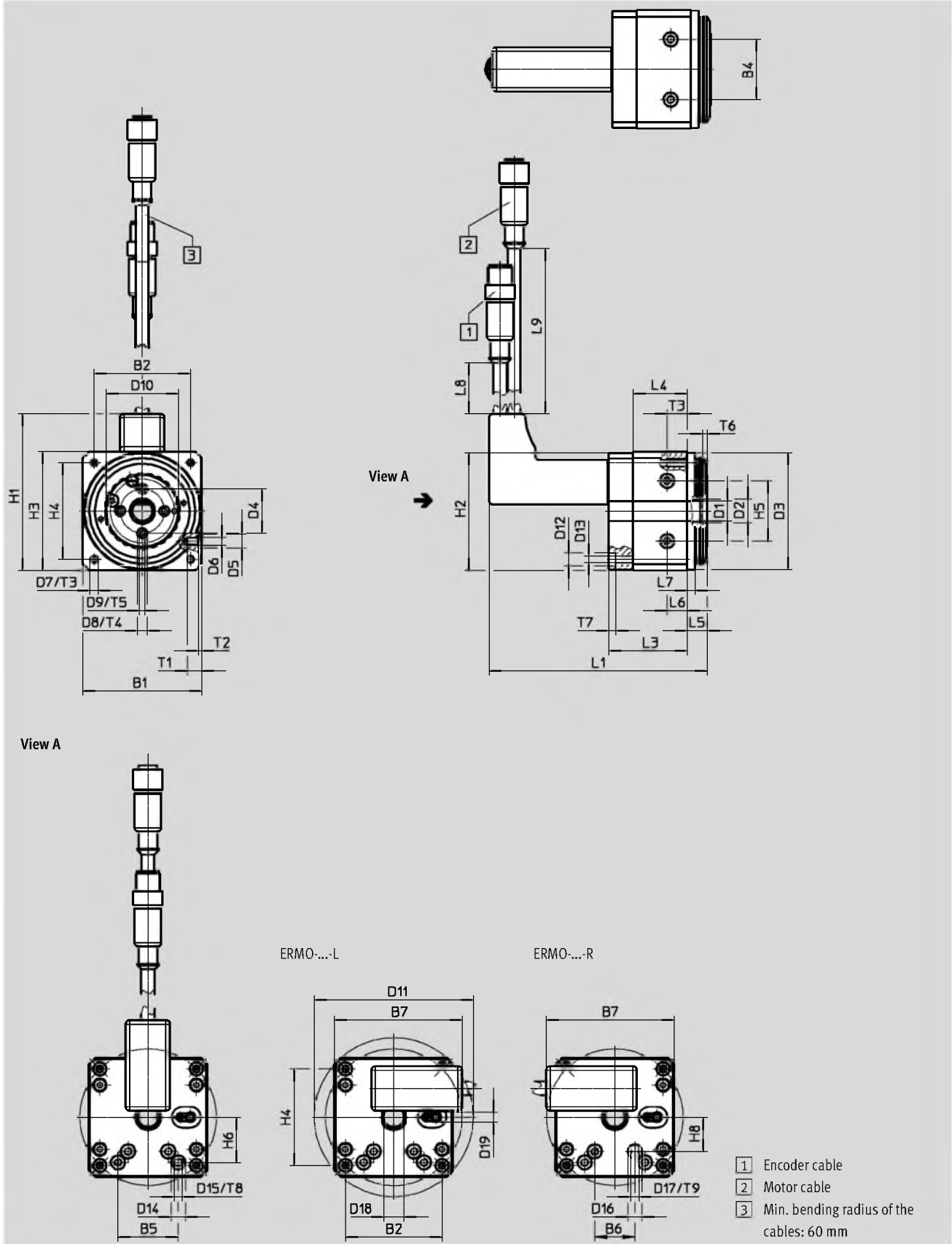

## Rotary drives ERMO, electric

Technical data

Size	B1	B2	B4	B5	B6	B7	D1	D2	D3	D4
	±0.3		±0.03	±0.02	±0.02		∅	∅ H8	∅ f8	∅ ±0.02
12	59	48	30	30	20	46	10	12	58	22

Size	D5	D6	D7	D8	D9	D10	D11	D12	D13	D14
	∅ H7			∅ H7		∅	∅ ±0.5	∅	∅	∅ H7
12	7	M4	M4	5	M3	36	79	6.5	3.4	7

Size	D15	D16	D17	D18	D19	H1	H2	H3	H4	H5
		∅ H7		max.				±0.3		±0.03
12	M4	7	M4	7	M5x0.5	80	58.5	59	48	30

Size	H6	H8	L1	L3	L4	L5	L6	L7	L8	L9
			±1.5	±0.6		±0.2	±0.1	±0.1		
12	22.5	17	100	39	27	10	10	4	300	300

Size	T1	T2	T3	T4	T5	T6	T7	T8	T9
		+0.1		+0.1		+0.1			
12	7	1.5	10	1.2	7	2.5	3.4	1.5	1.5

# Rotary drives ERMO, electric

Technical data

## Dimensions

Size 16

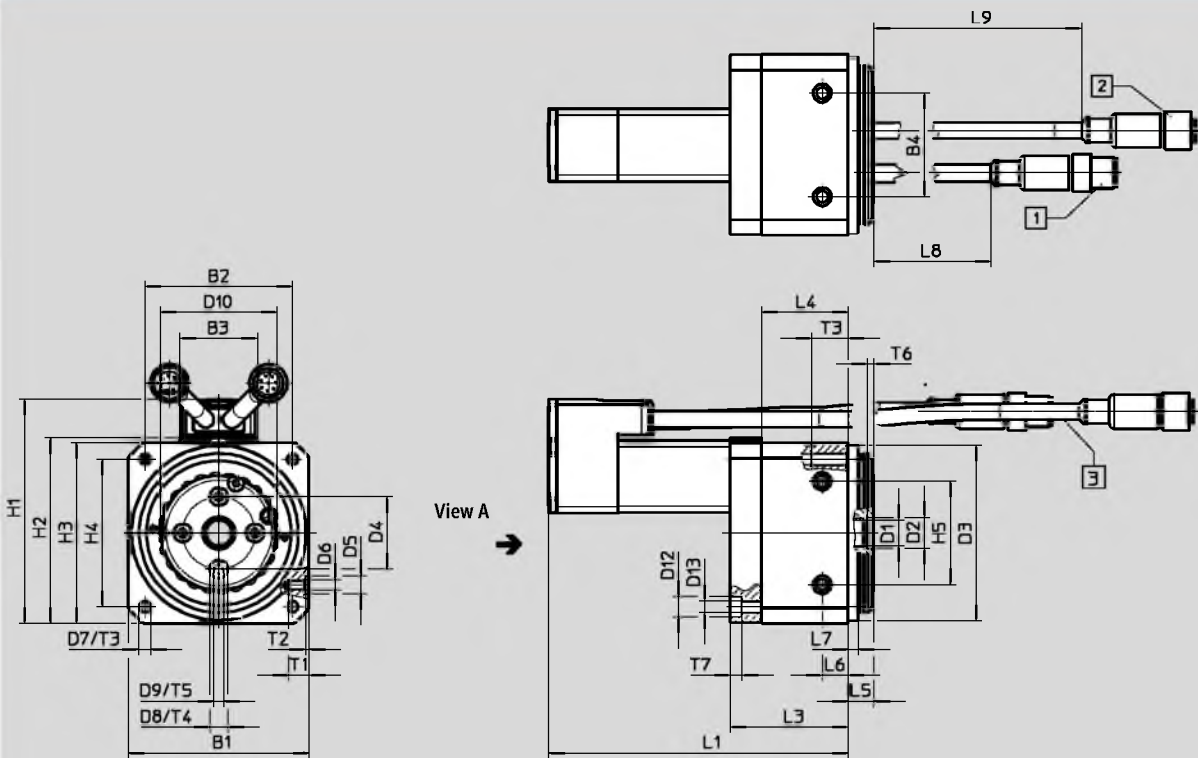

View A

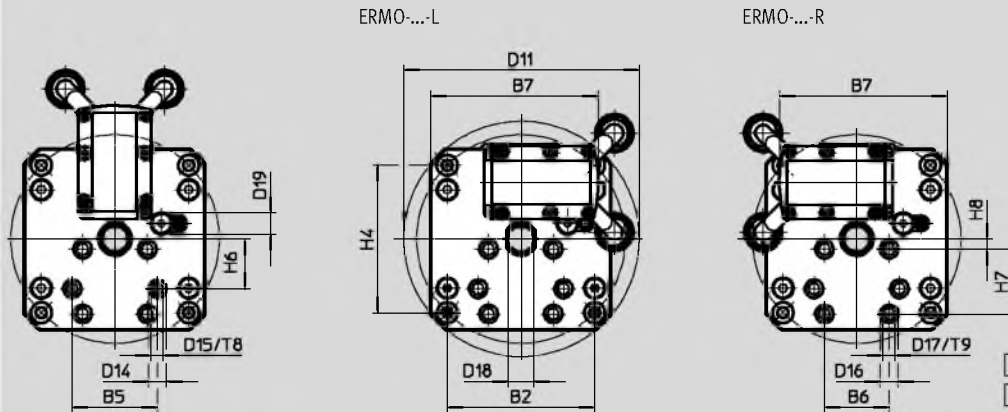

- 1 Encoder cable
- 2 Motor cable
- 3 Min. bending radius of the cables: 60 mm

# Rotary drives ERMO, electric

Technical data

Size	B1	B2	B3	B4	B5	B6	B7	D1 ∅	D2 ∅ H8	D3 ∅ f8	D4 ∅ ±0.02
16	±0.3 70	57	30	±0.03 40	±0.02 33	±0.02 25	65	10	12	68	28

Size	D5 ∅ H7	D6	D7	D8 ∅ H7	D9	D10 ∅	D11 ∅ ±0.5	D12 ∅	D13 ∅	D14 ∅ H7
16	7	M5	M5	7	M4	45	91	8	4.6	7

Size	D15	D16 ∅ H7	D17	D18 max.	D19	H1	H2	H3 ±0.3	H4	H5 ±0.03
16	M5	7	M5	–	M8x1	87	71.8	70	57	40

Size	H6	H7 ±0.02	H8	L1 ±1.5	L3 ±0.6	L4	L5 ±0.2	L6 ±0.1	L7 ±0.1	L8
16	19.3	25	4	116/142 <sup>1)</sup>	45.5	33.5	10	10	4	250

Size	L9	T1	T2 +0.1	T3	T4 +0.1	T5	T6 +0.1	T7	T8	T9
16	350	8	1.5	14	1.5	8	2.5	4.5	1.5	1.5

1) Motor with brake

# Rotary drives ERMO, electric

Technical data

## Dimensions

Size 25/32

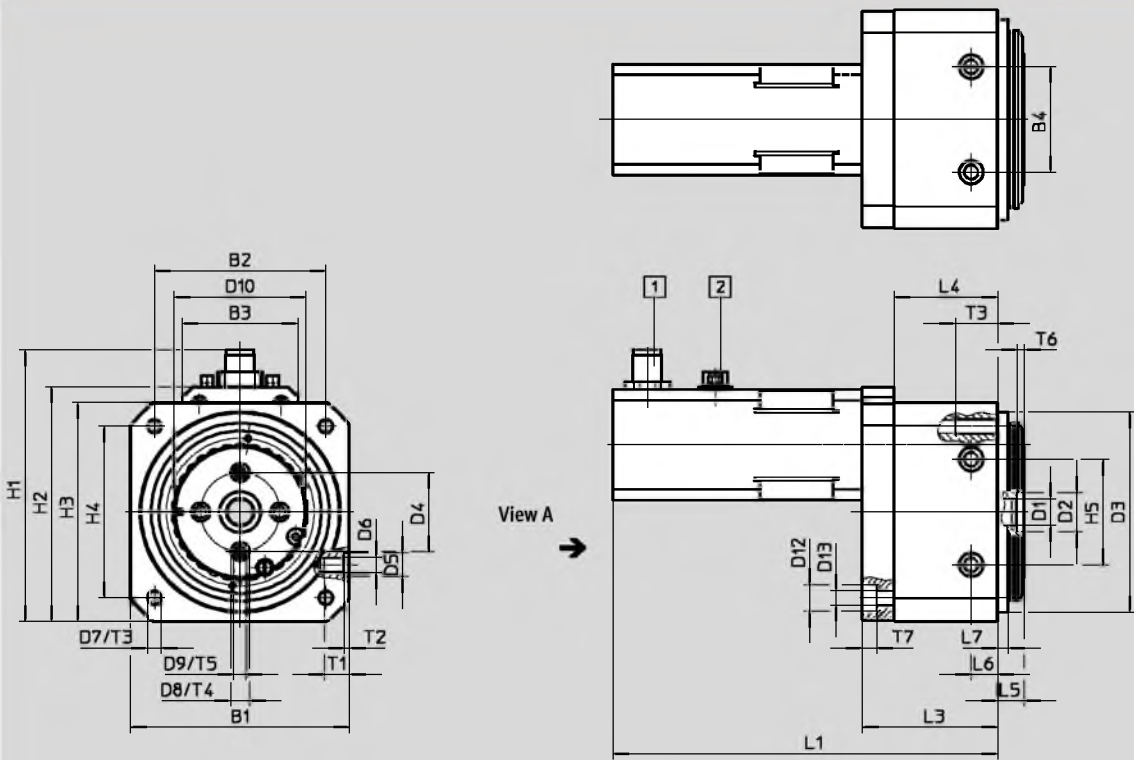

View A

ERMO-...-L

ERMO-...-R

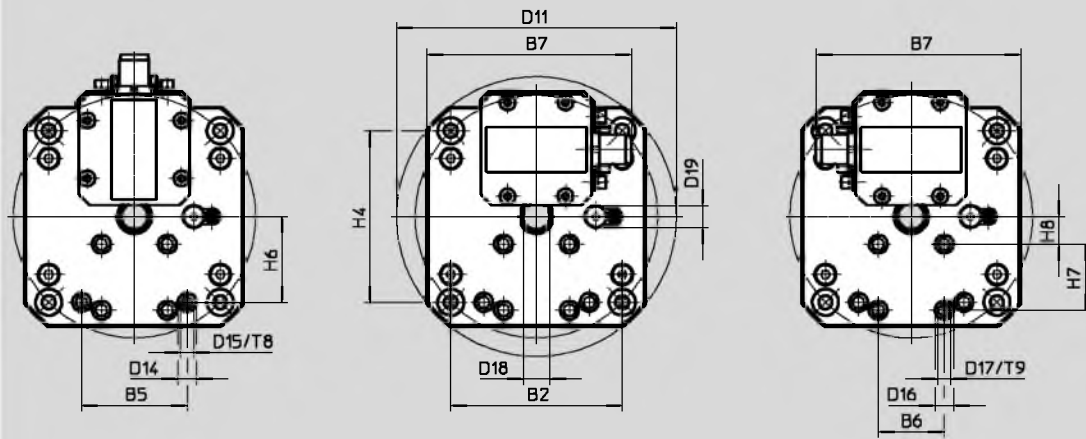

- 1 Encoder connection
- 2 Motor connection



# Rotary drives ERMO, electric

Technical data

Size	B1 ±0.3	B2	B3	B4 ±0.03	B5 ±0.02	B6 ±0.02	B7	D1 ∅	D2 ∅ H8	D3 ∅ f8	D4 ∅ ±0.02
25	83	65	44	40	40	25	78	10	15	76	30
32	105	85	58	60	-	25	96	16	20	96	42

Size	D5 ∅ H7	D6	D7	D8 ∅ H7	D9	D10 ∅	D11 ∅ ±0.5	D12 ∅	D13 ∅	D14 ∅ H7
25	9	M6	M6	7	M5	50	106	10	5.5	7
32	12	M 8	M 8	7	M5	65	135	11	6.6	-

Size	D15	D16 ∅ H7	D17	D18 max.	D19	H1	H2	H3 ±0.3	H4	H5 ±0.03
25	M5	7	M5	10	M8x1	103	89	83	65	40
32	-	7	M5	9	M8x1	125	110.5	105	85	60

Size	H6	H7 ±0.02	H8	L1 ±1.5	L3 ±0.6	L4	L5 ±0.2	L6 ±0.1	L7 ±0.1
25	32.5	25	10.5	146/179 <sup>1)</sup>	51.3	39.3	10	10	4
32	-	25	15	148/189 <sup>1)</sup>	46.5	34.5	12	10	6

Size	T1	T2 +0.1	T3	T4 +0.1	T5	T6 +0.1	T7	T8	T9
25	9.5	2	16	1.5	8.5	2.5	5.5	1.5	1.5
32	15	2.5	20	1.5	10	2.8	6.8	-	1.5

1) Motor with brake

## Rotary drives ERMO, electric

Technical data

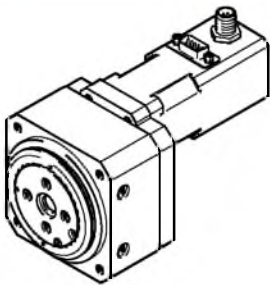
Ordering data			
	Size	Part No.	Type
	12	<b>3008525</b>	<b>ERMO-12-ST-E</b>
	16	<b>3008526</b>	<b>ERMO-16-ST-E</b>
	25	<b>3008527</b>	<b>ERMO-25-ST-E</b>
	32	<b>3008528</b>	<b>ERMO-32-ST-E</b>

# Rotary drives ERMO, electric

Ordering data - Modular products

Ordering table							
Size	12	16	25	32	Condi- tions	Code	Entry code
<b>M</b> Module no.	<b>2954695</b>	<b>2954696</b>	<b>2954697</b>	<b>2954698</b>			
Function	Electric cylinders					<b>ERMO</b>	ERMO
Size	12	16	25	32		*...	
Motor type	Stepper motor					<b>-ST</b>	-ST
Measuring unit	Encoder					<b>-E</b>	-E
<b>O</b> Brake	None						
	- With brake					<b>B</b>	
Cable outlet direction	Top (standard)						
	Left					<b>-L</b>	
	Right					<b>-R</b>	
Connecting cable to motor controller	Without						
	1.5 m, straight plug connector					<b>+1.5E</b>	
	2.5 m, straight plug connector					<b>+2.5E</b>	
	5 m, straight plug connector					<b>+5E</b>	
	7 m, straight plug connector					<b>+7E</b>	
	10 m, straight plug connector					<b>+10E</b>	
			1.5 m, angled plug connector			<b>+1.5EA</b>	
			2.5 m, angled plug connector			<b>+2.5EA</b>	
			5 m, angled plug connector			<b>+5EA</b>	
		7 m, angled plug connector			<b>+7EA</b>		
		10 m, angled plug connector			<b>+10EA</b>		
Controller type	None						
	CMMO, 5 A					<b>1</b> <b>+C5</b>	
Bus protocol/activation	None						
	Digital I/O interface					<b>DIO</b>	
	IO-Link					<b>LK</b>	
Switching input/output	None						
	NPN					<b>2</b> <b>N</b>	
	PNP					<b>P</b>	

**1** **DIO, LK, N, P** Must be selected if controller type +C5 is selected.

**2** **N** Not with IO-Link LK

**M** Mandatory data

**O** Options

### Transfer order code

**ERMO** -  - **ST** - **E**  -  +  +

# Rotary drives ERMO, electric

Accessories

## Stop kit EADP

Materials:

Housing: Anodised aluminium

Stops: Nickel-plated beryllium bronze

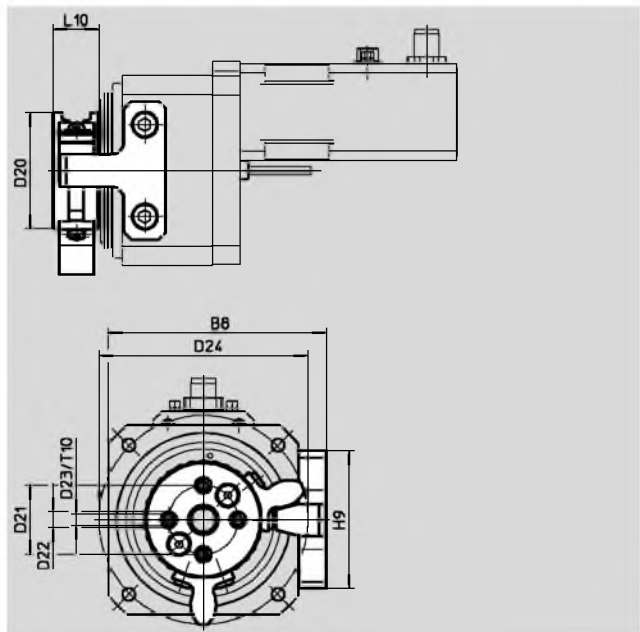
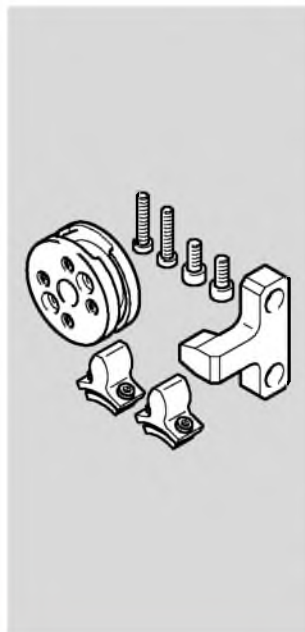



Dimensions and ordering data									
For size	B8	D20	D21	D22	D23	D24	H9	L10	T10
		∅	∅	∅		∅			
		±0.1	±0.1	H7				±0.1	
12	69	44	28	7	M4	74.8	40	16	16
16	80	44	28	7	M4	74.2	52	16	16
25	95	50.5	30	7	M5	91	60	20	20
32	120	64	42	7	M5	90	80	27	27



For size	Setting range for rotation angle		Weight [g]	Part No.	Type
	1 stop	2 stops			
12	0 ... 325	0 ... 280	96	3044562	EADP-ES-R3-12
16	0 ... 325	0 ... 280	100	2715501	EADP-ES-R3-16
25	0 ... 325	0 ... 270	210	2721599	EADP-ES-R3-25
32	0 ... 325	0 ... 270	290	2735411	EADP-ES-R3-32



## Rotary drives ERMO, electric

Accessories

Ordering data – Centring sleeves					
	For size	Description	Part No.	Type	
	12, 16	For centring the drive for lateral mounting	<b>186717</b>	<b>ZBH-7</b>	10
	25		<b>150927</b>	<b>ZBH-9</b>	
	32		<b>189653</b>	<b>ZBH-12</b>	
	12 ... 32	For centring attachments on the rotating plate	<b>186717</b>	<b>ZBH-7</b>	
	12, 16	For centring attachments in the middle of the rotating plate	<b>189653</b>	<b>ZBH-12</b>	1
	25		<b>191409</b>	<b>ZBH-15</b>	
	32		<b>150901</b>	<b>SLZZ-25/16</b>	





1) Packaging unit

Ordering data – Proximity sensor M5/M8 (round design), inductive						
	Switching element function	Electrical connection	LED	Switching output	Cable length [m]	Part No. Type
For size 12						
	N/O contact	Cable, 3-wire	■	PNP	2.5	<b>150370</b> <b>SIEN-M5B-PS-K-L</b>
		Plug connector M8x1, 3-pin			–	<b>150371</b> <b>SIEN-M5B-PS-S-L</b>
	N/C contact	Cable, 3-wire	■	PNP	2.5	<b>150374</b> <b>SIEN-M5B-PO-K-L</b>
		Plug connector M8x1, 3-pin			–	<b>150375</b> <b>SIEN-M5B-PO-S-L</b>
For size 16 ... 32						
	N/O contact	Cable, 3-wire	■	PNP	2.5	<b>150386</b> <b>SIEN-M8B-PS-K-L</b>
		Plug connector M8x1, 3-pin			–	<b>150387</b> <b>SIEN-M8B-PS-S-L</b>
	N/C contact	Cable, 3-wire	■	PNP	2.5	<b>150390</b> <b>SIEN-M8B-PO-K-L</b>
		Plug connector M8x1, 3-pin			–	<b>150391</b> <b>SIEN-M8B-PO-S-L</b>

Ordering data – Connecting cables				
	Electrical connection, left	Electrical connection, right	Cable length [m]	Part No.
	Straight socket, M8x1, 3-pin	Cable, open end, 3-wire	2.5	<b>159420</b> <b>SIM-M8-3GD-2,5-PU</b>
			2.5	<b>541333</b> <b>NEBU-M8G3-K-2.5-LE3</b>
			5.0	<b>541334</b> <b>NEBU-M8G3-K-5-LE3</b>
	Angled socket, M8x1, 3-pin	Cable, open end, 3-wire	2.5	<b>541338</b> <b>NEBU-M8W3-K-2.5-LE3</b>
			5.0	<b>541341</b> <b>NEBU-M8W3-K-5-LE3</b>

# Rotary drives ERMO, electric

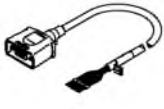
Accessories

Ordering data – Cables <sup>1)</sup>					
	For size	Description	Cable length [m]	Part No.	Type
<b>Motor cable</b>					
	12, 16	Straight plug connector – Min. bending radius: 62 mm – Suitable for use with energy chains – Ambient temp.: –40 ... +80 °C	1.5	1449600	NEBM-SM12G8-E-1.5-Q5-LE6
			2.5	1449601	NEBM-SM12G8-E-2.5-Q5-LE6
			5.0	1449602	NEBM-SM12G8-E-5-Q5-LE6
			7.0	1449603	NEBM-SM12G8-E-7-Q5-LE6
			10.0	1449604	NEBM-SM12G8-E-10-Q5-LE6
	25, 32	Angled plug connector – Min. bending radius: 62 mm – Suitable for use with energy chains – Ambient temp.: –40 ... +80 °C	1.5	1450736	NEBM-S1W9-E-1.5-Q5-LE6
			2.5	1450737	NEBM-S1W9-E-2.5-Q5-LE6
			5.0	1450738	NEBM-S1W9-E-5-Q5-LE6
			7.0	1450739	NEBM-S1W9-E-7-Q5-LE6
			10.0	1450740	NEBM-S1W9-E-10-Q5-LE6
	25, 32	Straight plug connector – Min. bending radius: 62 mm – Suitable for use with energy chains – Ambient temp.: –40 ... +80 °C	1.5	1450368	NEBM-S1G9-E-1.5-Q5-LE6
			2.5	1450369	NEBM-S1G9-E-2.5-Q5-LE6
			5.0	1450370	NEBM-S1G9-E-5-Q5-LE6
			7.0	1450371	NEBM-S1G9-E-7-Q5-LE6
			10.0	1450372	NEBM-S1G9-E-10-Q5-LE6
<b>Encoder cable</b>					
	12, 16, 25, 32	Straight plug connector – Min. bending radius: 68 mm – Suitable for use with energy chains – Ambient temp.: –40 ... +80 °C	1.5	1451586	NEBM-M12G8-E-1.5-LE8
			2.5	1451587	NEBM-M12G8-E-2.5-LE8
			5.0	1451588	NEBM-M12G8-E-5-LE8
			7.0	1451589	NEBM-M12G8-E-7-LE8
			10.0	1451590	NEBM-M12G8-E-10-LE8
	25, 32	Angled plug connector – Min. bending radius: 68 mm – Suitable for use with energy chains – Ambient temp.: –40 ... +80 °C	1.5	1451674	NEBM-M12W8-E-1.5-LE8
			2.5	1451675	NEBM-M12W8-E-2.5-LE8
			5.0	1451676	NEBM-M12W8-E-5-LE8
			7.0	1451677	NEBM-M12W8-E-7-LE8
			10.0	1451678	NEBM-M12W8-E-10-LE8

1) Other cable lengths on request.

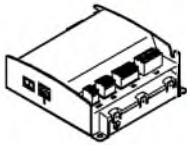
Ordering data – Motor controller			
	Description	Part No.	
	With I/O interface		
	Switching input/output PNP	1512316	CMMO-ST-C5-1-DIOP
	Switching input/output NPN	1512317	CMMO-ST-C5-1-DION
	With IO-Link		
	Switching input/output PNP	1512320	CMMO-ST-C5-1-LKP

:

(8182)63-90-72  
+7(7172)727-132  
(4722)40-23-64  
(4832)59-03-52  
(423)249-28-31  
(844)278-03-48  
(8172)26-41-59  
(473)204-51-73  
(343)384-55-89  
(4932)77-34-06  
(3412)26-03-58  
(843)206-01-48

(4012)72-03-81  
(4842)92-23-67  
(3842)65-04-62  
(8332)68-02-04  
(861)203-40-90  
(391)204-63-61  
(4712)77-13-04  
(4742)52-20-81  
(3519)55-03-13  
(495)268-04-70  
(8152)59-64-93  
(8552)20-53-41

(831)429-08-12  
(3843)20-46-81  
(383)227-86-73  
(4862)44-53-42  
(3532)37-68-04  
(8412)22-31-16  
(342)205-81-47  
- - (863)308-18-15  
(4912)46-61-64  
(846)206-03-16  
- (812)309-46-40  
(845)249-38-78

(4812)29-41-54  
(862)225-72-31  
(8652)20-65-13  
(4822)63-31-35  
(3822)98-41-53  
(4872)74-02-29  
(3452)66-21-18  
(8422)24-23-59  
(347)229-48-12  
(351)202-03-61  
(8202)49-02-64  
(4852)69-52-93